



SERVICE MANUAL

UHF TRANSCEIVER

IC-F43GT
IC-F43GS
IC-F44GT
IC-F44GS

S-14108IZ-C1-①
Apr. 2007

Icom Inc.

INTRODUCTION

This service manual describes the latest service information for the **IC-F43GT/GS IC-F44GT/GS** UHF TRANSCEIVER at the time of publication.

MODEL	VERSION	FREQUENCY RANGE	CHANNEL SPACING
IC-F43GT (Ten-key)	MTG-01	400–470 MHz	12.5/25.0 kHz
	USA-01		
	USA-02	450–512 MHz	
	USA-03	380–430 MHz	
	USA-04	400–470 MHz	
	GEN-01		
	GEN-02	450–520 MHz	
	AUS-02		
CHN-01	400–470 MHz		
IC-F44GT (Ten-key)	MTE-01	400–470 MHz	12.5/25.0 kHz
	EUR-01		12.5/20.0/25.0 kHz
IC-F43GS (4-key)	MTG-01	400–470 MHz	12.5/25.0 kHz
	USA-01		
	USA-02	450–512 MHz	
	USA-03	380–430 MHz	
	USA-04	400–470 MHz	
	GEN-01		
	GEN-02	450–520 MHz	
	AUS-02		
CHN-01	400–470 MHz		
IC-F44GS (4-key)	MTE-01	400–470 MHz	12.5/25.0 kHz
	EUR-01		12.5/20.0/25.0 kHz

To upgrade quality, any electrical or mechanical parts and internal circuits are subject to change without notice or obligation.

CAUTION

NEVER connect the transceiver to an AC outlet or to a DC power supply that uses more than 8 V. This will ruin the transceiver.

DO NOT expose the transceiver to rain, snow or any liquids.

DO NOT reverse the polarities of the power supply when connecting the transceiver.

DO NOT apply an RF signal of more than 20 dBm (100 mW) to the antenna connector. This could damage the transceiver's front-end.

ORDERING PARTS

Be sure to include the following four points when ordering replacement parts:

- 10-digit Icom parts numbers
- Component name
- Equipment model name and unit name
- Quantity required

<ORDER EXAMPLE>

1110003491 S.IC TA31136FNG IC-F43GT MAIN UNIT 5 pieces
8820001210 Screw 2438 screw IC-F43GT Top cover 10 pieces

Addresses are provided on the inside back cover for your convenience.

Icom, Icom Inc. and ICOM logo are registered trademarks of Icom Incorporated (Japan) in the United States, the United Kingdom, Germany, France, Spain, Russia and/or other countries.



REPAIR NOTES

1. Make sure the problem is internal before disassembling the transceiver.
2. **DO NOT** open the transceiver until the transceiver is disconnected from its power source.
3. **DO NOT** force any of the variable components. Turn them slowly and smoothly.
4. **DO NOT** short any circuits or electronic parts. An insulated tuning tool **MUST** be used for all adjustments.
5. **DO NOT** keep power ON for a long time when the transceiver is defective.
6. **DO NOT** transmit power into a Standard Signal Generator or a Sweep Generator.
7. **ALWAYS** connect a 50 dB to 60 dB attenuator between the transceiver and a Deviation Meter or Spectrum Analyzer when using such test equipment.
8. **READ** the instructions of test equipment thoroughly before connecting a test equipment to the transceiver.

CONTENTS

SECTION 1 SPECIFICATIONS

SECTION 2 INSIDE VIEWS

SECTION 3 DISASSEMBLY INSTRUCTIONS

SECTION 4 OPTIONAL UNITS INSTALLATION

SECTION 5 CIRCUIT DESCRIPITON

5-1	RECEIVER CIRCUITS.....	5-1
5-2	TRANSMITTER CIRCUITS.....	5-2
5-3	PLL CIRCUITS	5-4
5-4	POWER SUPPLY CIRCUITS.....	5-4
5-5	OTHER CIRCUITS	5-5
5-6	PORT ALLOCATIONS.....	5-5

SECTION 6 ADJUSTMENT PROCEDURES

6-1	PREPARATION	6-1
6-2	FREQUENCY ADJUSTMENT.....	6-2

SECTION 7 PARTS LIST

SECTION 8 MECHANICAL PARTS

SECTION 9 BOARD LAYOUTS

SECTION 10 VOLTAGE DIAGRAM

10-1	MAIN UNIT	10-1
10-2	PA/ANT/FUSE UNITS	10-3

SECTION 11 BC-160

SECTION 1

SPECIFICATIONS

■ GENERAL

• Frequency coverage	: 380.000–430.000 MHz 450.000–512.000 MHz 450.000–520.000 MHz 350.000–390.000 MHz 400.000–470.000 MHz	[USA-03] [USA-01], [USA-02], [USA-04] [GEN-01], [GEN-02] [GEN-04] [others]
• Mode	: FM	
• Type of emission	: Wide: 16K0F3E (25.0 kHz) Middle: 14K0F3E (20.0 kHz) Narrow: 11K0F3E/8K50F3E (12.5 kHz)	
• Number of conventional channels	: 250 ch (LTR/PassPort) 256 ch (16 banks) 32 ch (MPT)	
• Antenna impedance	: 50 Ω (nominal)	
• Operating temperature range	: –30°C to +60°C (–22°F to +140°F) –25°C to +55°C	except [F44GT/GS] [F44GT/GS]
• Power supply requirement	: 7.2 V DC nominal (negative ground)	
• Current drain (at 7.2 V DC)	: Receiving 85 mA (stand-by) 300mA (max. audio) Transmitting 1.7 A (4 W) 0.8 A (1 W)	
• Dimensions (projections not included)	: 53.0(W) × 120.0(H) × 32.5(D) mm; 2 ³ / ₃₂ (W) × 4 ² / ₃₂ (H) × 1 ⁹ / ₃₂ (D) in	
• Weight (with BP-230N+FA-SC57U+MB-94)	: 300 g; 10 ³ / ₈ oz (Approx.)	

■ TRANSMITTER

• Output power (at 7.2 V DC)	: High: 4 W, Low: 1 W	
• Modulation	: Variable reactance frequency modulation	
• Maximum permissible deviation	: ±5.0 kHz (Wide), ±4.0 kHz (Middle), ±2.5 kHz (Narrow)	
• Frequency error	: ±2.0 ppm; ±1.5 kHz	
• Spurious emissions	: 70 dB (typical) 0.25 μW (≤1 GHz), 1.0 μW (≥1 GHz)	except [F44GT/GS] [F44GT/GS]
• Adjacent channel power	: 70 dB min. (Wide/Middle) 60 dB min. (Narrow)	
• Audio harmonic distortion	: 3% typical (at 1 kHz, 40% deviation)	
• Limiting charact of modulator	: 60–100% of maximum deviation	
• FM hum and noise	: 40 dB min. 46 dB typ. (Wide) 34 dB min 40 dB typ. (Narrow)	
• Microphone impedance	: 2.2 kΩ	

■ RECEIVER

• Receive system	: Double conversion superheterodyne system	
• Intermediate frequencies	: 1st IF: 46.35 MHz, 2nd IF: 450 kHz 1st IF: 47.25 MHz, 2nd IF: 450 kHz	[others] [USA-03], [GEN-04]
• Sensitivity	: 0.25 μV (–119 dBm) typical at 12 dB SINAD –4 dBμV (–111 dBm) emf typ. at 20 dB SINAD	except [F44GT/GS] [F44GT/GS]
• Squelch sensitivity (at threshold)	: 0.25 μV typical –4 dBμV (–111 dBm) emf typ.	
• Adjacent channel selectivity	: 70 dB min (75 dB typical) for Wide 70 dB min (73 dB typical) for Wide 60 dB min (65 dB typical) for Narrow 60 dB min (63 dB typical) for Narrow	except [F44GT/GS] [F44GT/GS] except [F44GT/GS] [F44GT/GS]
• Spurious response	: 70 dB	
• Intermodulation rejection ratio	: 70 dB min (74 dB typical) 65 dB min (67 dB typical)	except [F44GT/GS] [F44GT/GS]
• Audio output power	: 0.5 W typical at 5% distortion with an 8 Ω load	
• Output impedance (Audio)	: 8 Ω	

Specifications are measured in accordance with EIA-152-C/204D, TIA-603 or EN 300 086.

All stated specifications are subject to change without notice or obligation.

SECTION 2

INSIDE VIEWS

• MAIN UNIT

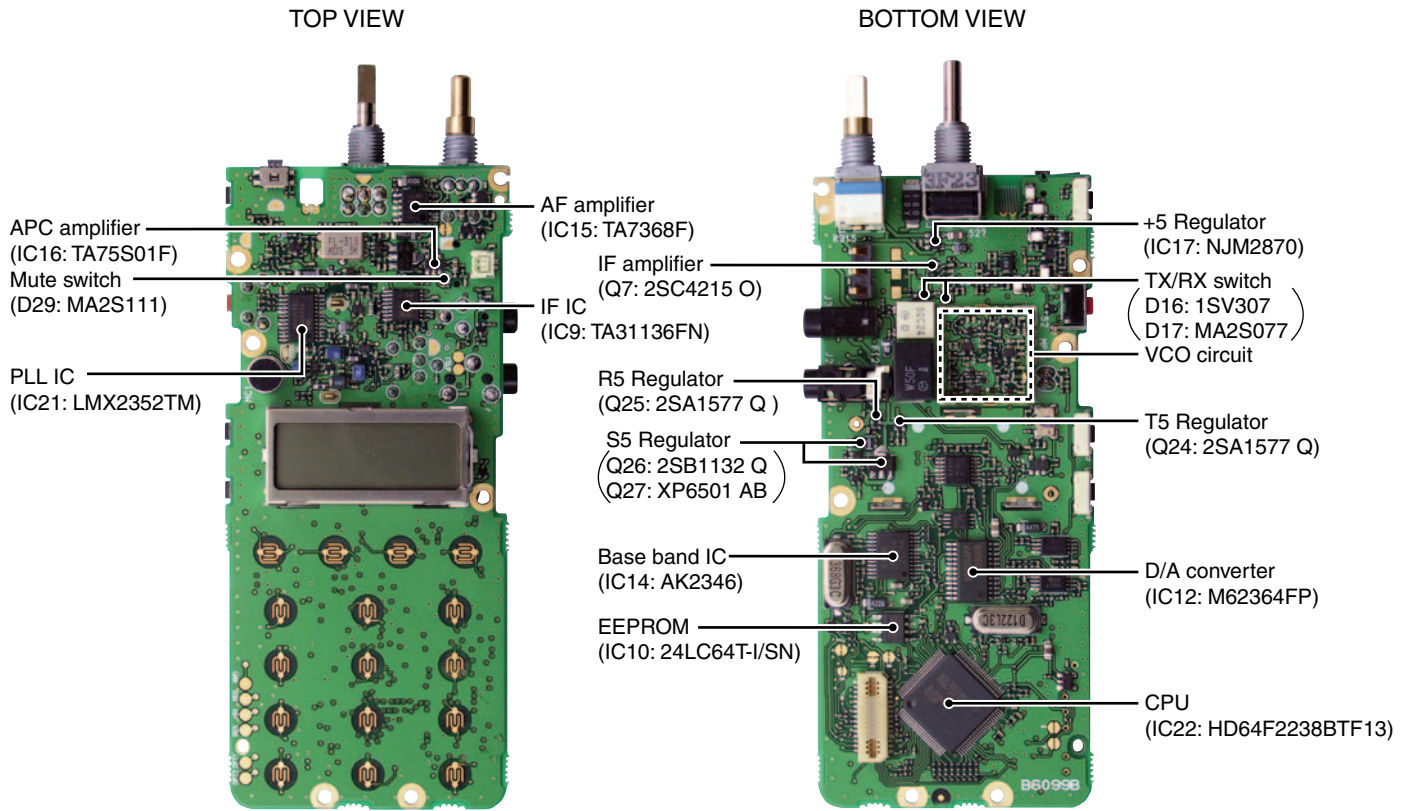

• PA UNIT

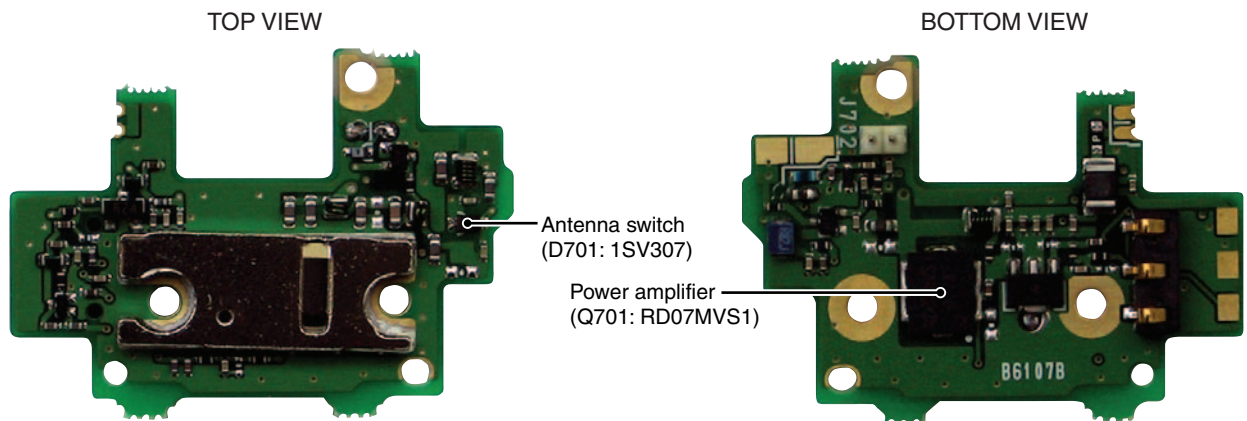

SECTION 3 DISASSEMBLY INSTRUCTION

• REMOVING THE CHASSIS UNIT

- ① Unscrew 1 nut (A), and remove 2 knobs (B), (C).
- ② Unscrew 2 screws (D).
- ③ Unscrew 2 screws (E).
- ④ Take off the chassis unit in the direction of the arrow.
- ⑤ Unplug the connector (F) from the chassis unit.

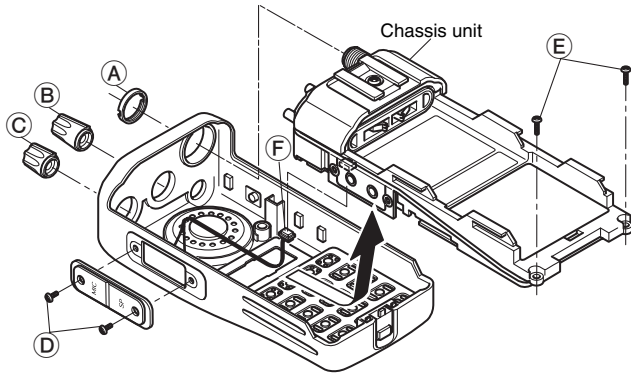

• REMOVING THE PA UNIT

- ① Unscrew 3 screws (M).
- ② Unsolder 4 points (N), and take off the PA unit in the direction of the arrow.

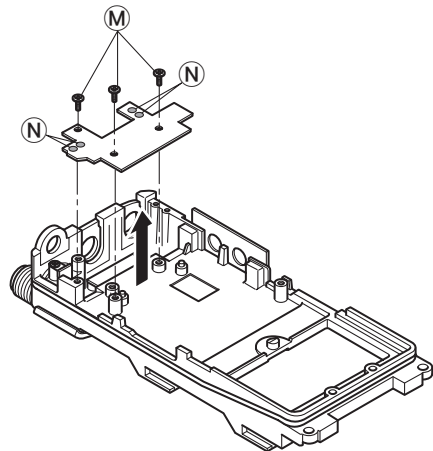

• REMOVING THE MAIN UNIT

- ① Unscrew 2 nuts (G), and remove the top plate (H).
- ② Remove the side plate (I).
- ③ Unscrew 6 screws (J).
- ④ Unsolder 8 points (K), and remove the main shield.
- ⑤ Unsolder 2 points (L), and take off the main unit in the direction of the arrow.

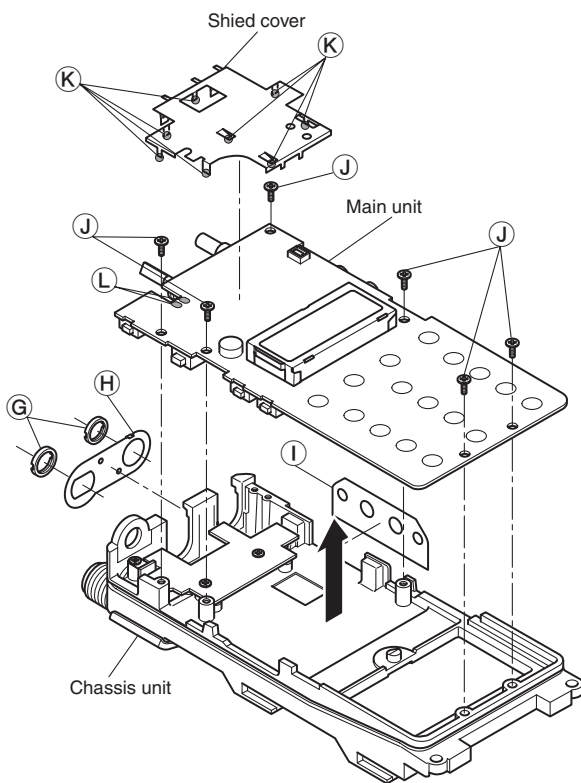

SECTION 4 OPTIONAL UNIT INSTALLATION

Install the optional unit as follows:

① Rotate [VOL] to turn the power OFF, and remove the battery pack.

② Remove the unit cover.

NOTE: Use a flat head screw driver or a similar flat instrument, and insert into the hollow of the chassis, then lift and take away the unit cover.

Use the supplied spare unit cover! Do not use the cover that has been removed once. Water or dust may get into the transceiver because the cover may be bent or has lost its adhesion. This may result in the transceiver being damaged.

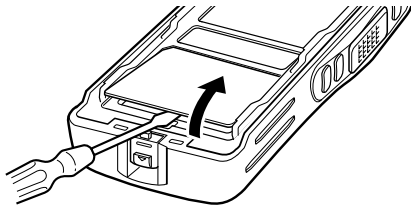

③ Install the unit as shown below.

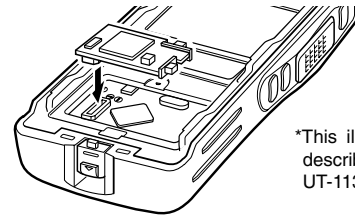

*This illustration is described with the UT-113.

④ Replace the unit cover and the battery pack, then rotate [VOL] to turn the power ON.

NOTE: The optional UT-109/UT-110 SCRAMBLER UNITS, UT-105 SmarTrunk II™ LOGIC BOARD or UT-117/UT-117S SmarTrunk 3G™ LOGIC BOARD requires some PC board modifications. Please refer to the additional installation on next page.

■ UT-109 and UT-110 installation

The following PC board modification is required when installing the optional UT-109 or UT-110:

① Rotate [VOL] to turn the power OFF, and remove the battery pack.

② Remove the unit cover as shown above.

③ Cut the pattern on the PCB at the TX mic circuit (MIC) and RX AF circuit (DISC) as shown below.

④ Install the scrambler unit as described above.

⑤ Replace the unit cover and the battery pack, then rotate [VOL] to turn the power ON.

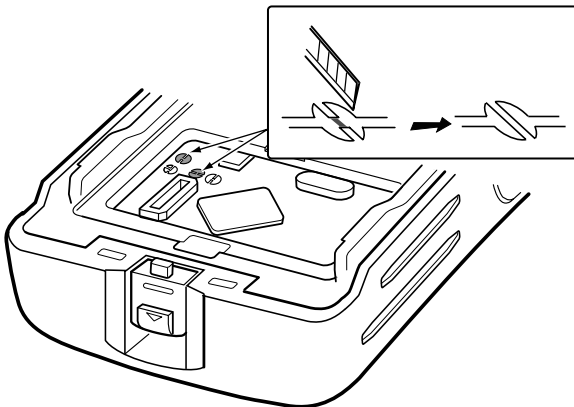

NOTE: When uninstalling the scrambler unit

Be sure to re-solder the disconnected points at left, otherwise no TX modulation or AF output is available.

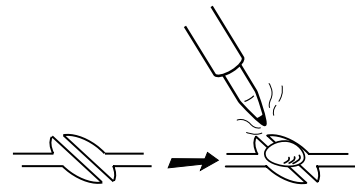

■ UT-105, UT-117 and UT-117S installation

The following PC board modification is required when installing the optional UT-105, UT-117 or UT-117S:

- ① Rotate **[VOL]** to turn the power OFF, and remove the battery pack.
- ② Remove the unit cover as described above.
- ③ Cut and solder the pattern on the PCB at the RX AF circuit as shown at right.
- /// The next step ④ is necessary for the UT-117S installation.
- /// Go to step ⑤ to install the UT-105 or UT-117.

- ④ Cut the pattern on the PCB at the TX mic circuit (MIC) and RX AF circuit (DISC) as shown at right.
- ⑤ Install the UT-105/UT-117/UT-117S as described above.
- ⑥ Replace the unit cover and the battery pack, then rotate **[VOL]** to turn the power ON.

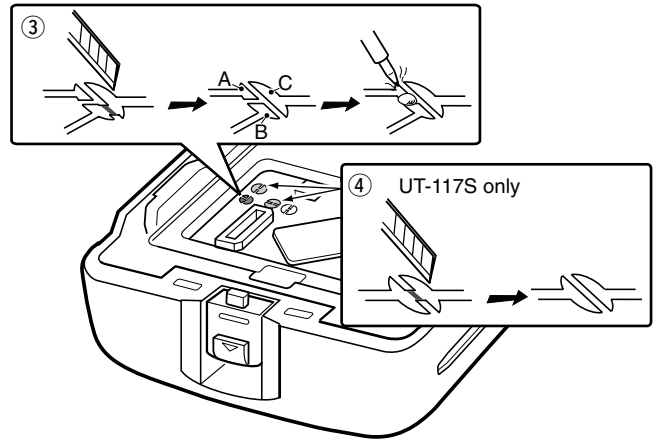

/// **NOTE: When uninstalling the SmarTrunk 3G™ unit**
Be sure to un-solder A and B, and re-solder B and C as shown below, otherwise no AF output is available.
Moreover, the UT-117S is required to re-solder the TX mic circuit (MIC) and RX AF circuit (DISC).

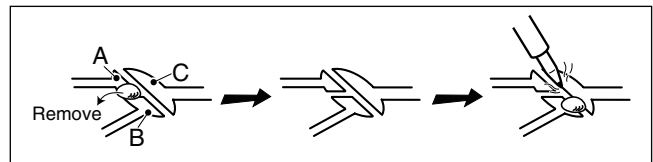

5-1 RECEIVER CIRCUITS

5-1-1 ANTENNA SWITCHING CIRCUIT (PA UNIT)

The antenna switching circuit functions as a low-pass filter while receiving and a resonator circuit while transmitting. This circuit does not allow transmit signals to enter the receiver circuits. Received signals enter the antenna connector (CHASSIS; J1) and pass through the low-pass filter (ANT unit; L801, L802, C803, C806). The filtered signals are passed through the 1/4 type antenna switching circuit (D701, D704, L712) and then applied to the RF circuit.

5-1-2 RF CIRCUIT (MAIN UNIT)

The RF circuit amplifies signals within the range of frequency coverage and filters out-of-band signals.

The signals from the antenna switching circuit pass through the two-stage tunable bandpass filters (D19, D20, D24, D25, L7, L8, C27, C369). The filtered signals are amplified at the RF amplifier (Q5) and then passed through the another twostage tunable bandpass filters (D14, D15, C39, C45) to suppress unwanted signals. The filtered signals are applied to the 1st mixer circuit. D14, D15, D19, D20, D24 and D25 employ varactor diodes, that are controlled by the CPU via the D/A converter (IC12), to track the bandpass filter. These varactor diodes tune the center frequency of an RF passband for wide bandwidth receiving and good image response rejection.

5-1-3 1ST MIXER AND 1ST IF CIRCUITS (MAIN UNIT)

The 1st mixer circuit converts the received signal into fixed frequency of the 1st IF signal with the PLL output frequency.

By changing the PLL frequency, only the desired frequency passes through a crystal filter at the next stage of the 1st mixer.

The RF signals from the bandpass filter are mixed with the 1st LO signals, where come from the RX VCO circuit via the low-pass filter (L46, C396, C397), at the 1st mixer circuit (Q6) to produce a 46.35 MHz 1st IF signal. The 1st IF signal is passed through a monolithic filter (F11) in order to obtain selection capability and to pass only the desired signals. The filtered signal is applied to the 2nd IF circuit after being amplified at the 1st IF amplifier (Q7).

5-1-4 2ND IF AND DEMODULATOR CIRCUITS (MAIN UNIT)

The 2nd mixer circuit converts the 1st IF signal into a 2nd IF signal. The double-conversion superheterodyne system (which convert receive signals twice) improves the image rejection ratio and obtains stable receiver gain.

The 1st IF signal from the IF amplifier (Q7) is applied to the 2nd mixer section of the FM IF IC (IC9, pin 16), and is mixed with the 2nd LO signal to be converted into a 450 kHz 2nd IF signal. The FM IF IC (IC9) contains the 2nd mixer, 2nd local oscillator, limiter amplifier, quadrature detector, active filter and noise amplifier circuits. A 2nd LO signal (45.9 MHz) is produced at the PLL circuit by tripling it's reference frequency (15.3 MHz).

• 2ND IF AND DEMODULATOR CIRCUITS

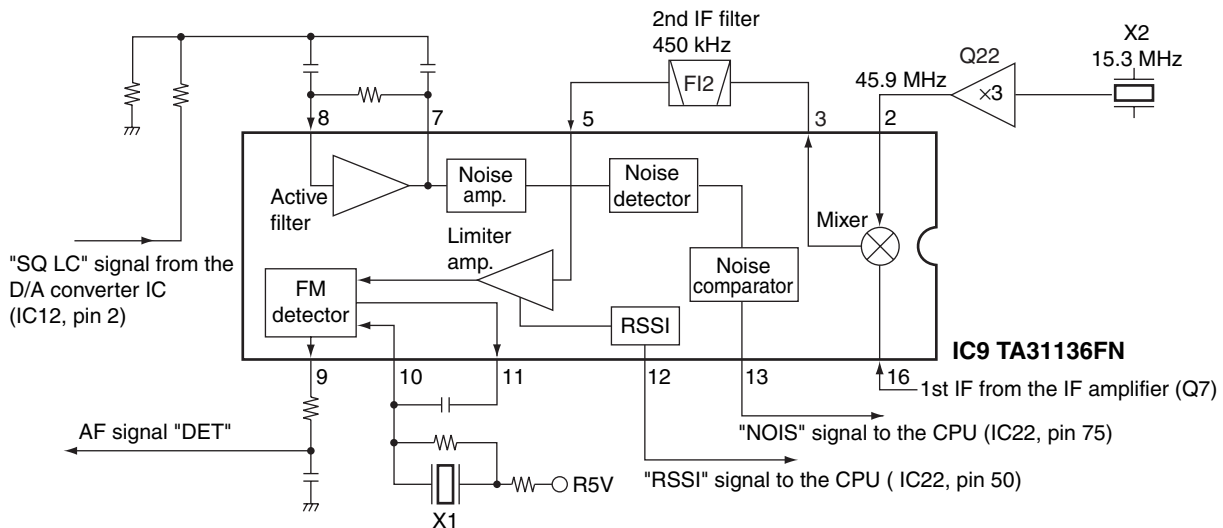

The 2nd IF signal from the 2nd mixer (IC9, pin 3) passes through the ceramic filter (F12) to remove unwanted heterodyned frequencies. It is then amplified at the limiter amplifier section (IC9, pin 5) and applied to the quadrature detector section (IC9, pins 10, 11) to demodulate the 2nd IF signal into AF signals.

The demodulated AF signals are output from pin 9 (IC9) and applied to the base band IC (IC14).

5-1-5 AF AMPLIFIER CIRCUIT (MAIN UNIT)

The AF amplifier circuit amplifies the demodulated AF signals to drive a speaker. This transceiver employs the base band IC which is composed of pre-amplifier, expander, scrambler, MSK de-modulator, etc. at the AF amplifier section.

The AF signals from the FM IF IC (IC9, pin 9) are amplified at the AF amplifier section in the base band IC (IC14, pin 23), and are then applied to the high-pass filter and low-pass filter section of it.

The filtered signals pass through the high-pass filter to suppress unwanted harmonic components. The signals pass through (or bypass) scrambler and expander sections. The signals are amplified at the amplifier section in the base band IC (IC14).

The output signals from IC14 (pin 20) pass through the lowpass filter section (IC23), and are then applied to the AF volume (R315), and AF power amplifier (IC15).

5-1-6 SQUELCH CIRCUITS (MAIN UNIT)

• NOISE SQUELCH

A squelch circuit cuts out AF signals when no RF signals are received. By detecting noise components in the AF signals, the squelch circuit switches the AF amplifier control.

Some noise components in the AF signals from the FM IF IC (IC9, pin 9) are passed through the D/A converter (IC12, pin 1). The signals are applied to the active filter section in the FM IF IC (IC9, pin 8). The active filter section filters and amplifies noise components. The amplified signals are converted into the pulse-type signals at the noise detector section. The detected signals output from pin 13 (NOIS) via the noise comparator section.

The "NOIS" signal from the FM IF IC is applied to the CPU (IC22, pin 75). Then the CPU analyzes the noise condition and outputs the AF mute signal as "AFON" from the pin 70 to the AF power controller (Q41, Q42).

• CTCSS AND DTCS

The tone squelch circuit detects tone signals and opens the squelch only when receiving a signal containing a matching subaudible tone (CTCSS or DTCS). When tone squelch is in use, and a signal with a mismatched or no subaudible tone is received, the tone squelch circuit mutes the AF signals even when noise squelch is open.

A portion of the "DET" AF signals from the FM IF IC (IC9, pin 9) pass through the low-pass filter (IC19, pin 5) to remove AF (voice) signals, and are then applied to the amplifier (IC19, pin 3). The amplified signals are applied to the CTCSS or DTCS decoder in the CPU (IC22, pin 46) via the "CDEC" line. The CPU outputs AF mute control signal and tone mute circuit (Q502) controls via the "MUTE" line.

5-2 TRANSMITTER CIRCUITS

5-2-1 MICROPHONE AMPLIFIER CIRCUIT (MAIN UNIT)

The microphone amplifier circuit amplifies audio signals within +6 dB/octave pre-emphasis characteristics from the microphone to a level needed for the modulation circuit. This transceiver employs the base band IC which is com-

• AF AND MIC AMPLIFIER CIRCUITS

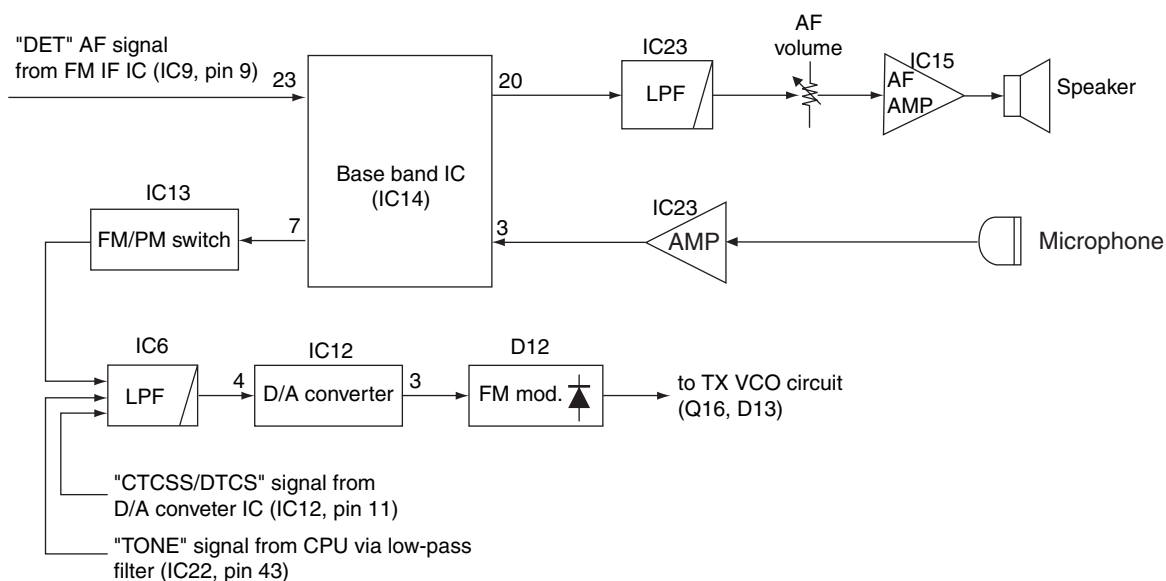

posed of microphone amplifier, compressor, scrambler, limiter, splatter filter, MSK modulator, etc. at the microphone amplifier section.

The AF signals (MIC) from the microphone (MC1) are applied to the amplifier (IC23, pins 6, 7). The amplified signals are applied to the microphone amplifier section of the base band IC (IC14, pins 3, 4). The amplified signals are passed through or bypass the compressor, scrambler sections of IC14, and are then passed through the high-pass, limiter amplifier, splatter filter sections of IC14.

The filtered AF signals are applied to the FM/PM switch (IC13, pin 6), and pass through the low-pass filter (IC6, pin 2). The filtered signals are applied to the D/A converter (IC12, pin 4). The output signals from the D/A converter (IC12, pin 3) are applied to the modulation circuit (D12).

5-2-2 MODULATION CIRCUIT (MAIN UNIT)

The modulation circuit modulates the VCO oscillating signal (RF signal) using the microphone audio signals.

The AF signals from the D/A converter (IC12, pin 3) change the reactance of varactor diode (D12) to modulate the oscillated signal at the TX VCO circuit (Q16, D10). The modulated VCO signal is amplified at the buffer amplifiers (Q15, Q29) and is then applied to the drive amplifier circuit via the T/R switch (D16).

The CTCSS/DTCS signals ("CENC0", "CENC1", "CENC2" from the CPU (IC22, pins 13, 15, 16) pass through the lowpass filter (IC6, pins 12, 14), and are then applied to the D/A converter via the "TONC" line (IC12, pin 12). The output signal from the D/A converter (IC12, pin 11) are mixed with "MOD" signal after pass through the low-pass filter (IC6).

The mixed signals are applied to the D/A converter (IC12, pin 3, 4), and are then applied to the D12 in the VCO circuit.

5-2-3 DRIVE/POWER AMPLIFIER CIRCUITS (PA UNIT)

The drive/power amplifier circuits amplify the VCO oscillating signal to an output power level.

The signal from the VCO circuit passes through the T/R switch (MAIN unit; D16), and is amplified at the YGR (Q703, Q704), drive (Q702), power (Q701) amplifiers to obtain 4 W of RF power (at 7.2 V DC).

The amplified signal is passed through the low-pass filter (L704, C711, C712, C713, C755), power detector (D702, D703), antenna switching circuit (D701) and another lowpass filters (PA unit; L709, C744, C745), (ANT unit; L801, L802, C802, C803, C804, C805), and is then applied to the antenna connector (CHASSIS unit; J1).

The bias current of the drive (Q702) and power (Q701) amplifiers are controlled by the APC circuit.

5-2-4 APC CIRCUIT (PA AND MAIN UNITS)

The APC circuit protects the drive and power amplifiers from excessive current drive, and selects output power of HIGH or LOW.

The power detector circuit (PA unit; D702, D703) detects the transmit power output level and converts it into DC voltage. The output voltage is at a minimum level when the antenna impedance is matched with 50 Ω and is increased when it is mismatched.

The detected voltage is applied to the differential amplifier

• APC CIRCUIT

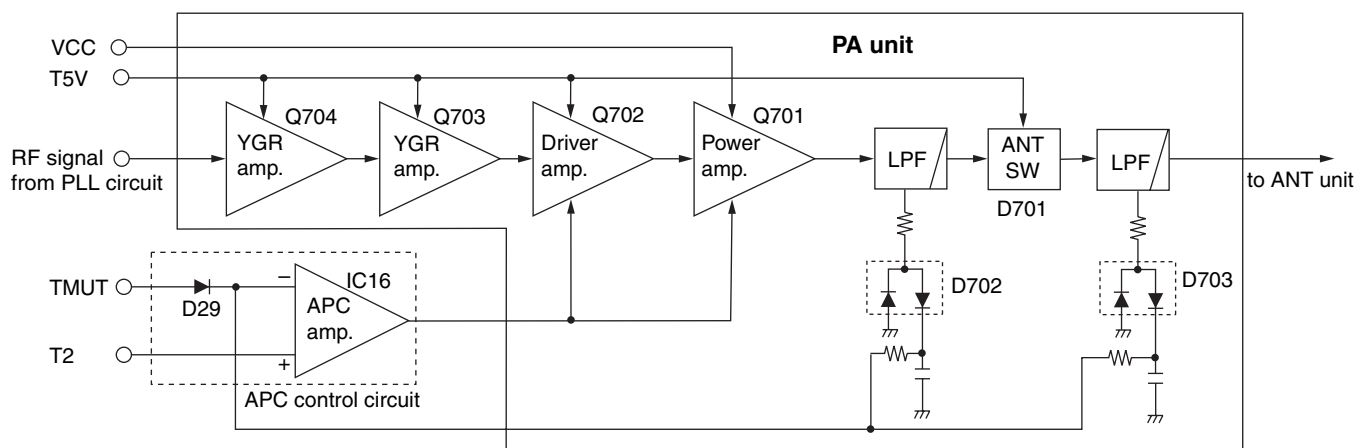

(MAIN unit; IC16; pin 3), and the "T2" signal from the D/A converter (MAIN unit; IC12, pin 23), controlled by the CPU (MAIN unit; IC22), is applied to the other input for reference.

When antenna impedance is mismatched, the detected voltage exceeds the power setting voltage. Then the output voltage of the differential amplifier (MAIN unit; IC16, pin 4) controls the input current of the drive (PA unit; Q702) and power (PA unit; Q701) amplifiers to reduce the output power.

5-3 PLL CIRCUITS

5-3-1 PLL CIRCUIT (MAIN UNIT)

A PLL circuit provides stable oscillation of the transmit frequency and receive 1st LO frequency. The PLL output compares the phase of the divided VCO frequency to the reference frequency. The PLL output frequency is controlled by the divided ratio (N-data) of a programmable divider.

The PLL circuit contains the TX and RX VCO circuits (Q16, Q17, D9–D13). The oscillated signal is amplified at the buffer amplifiers (Q14, Q15) and then applied to the PLL IC (IC21, pin 6) after being passed through the low-pass filter (L32, C206, C208).

The PLL IC contains a prescaler, programmable counter, programmable divider and phase detector, etc. The applied signal is divided at the prescaler and programmable counter section by the N-data ratio from the CPU. The divided signal is detected on phase at the phase detector using the reference frequency.

If the oscillated signal drifts, its phase changes from that of the reference frequency, causing a lock voltage change to compensate for the drift in the oscillated frequency.

5-3-2 VCO CIRCUITS (MAIN UNIT)

The VCO circuits contains a separate RX VCO (Q17, D9, D11) and TX VCO (Q16, D10, D12, D13). The oscillated signal is amplified at the buffer amplifiers (Q15, Q29) and is then applied to the T/R switch (D16, D17). Then the receive 1st LO (Rx) signal is applied to the 1st mixer (Q6) and the transmit (Tx) signal to the YGR amplifier circuit (PA unit; Q704).

A portion of the signal from the buffer amplifier (Q15) is fed back to the PLL IC (IC21, pin 6) via the buffer amplifier (Q14) as the comparison signal.

5-4 POWER SUPPLY CIRCUITS

LINE	DESCRIPTION
VCC	The voltage from the connected battery pack.
+5V	Common 5 V converted from the VCC line at the +5 regulator circuit (IC17). The output voltage is supplied to buffer amplifiers (Q21), PLL IC (IC21), etc.
S5V	Common 5 V converted from the VCC line at the S5 regulator circuit (Q26–Q28). The output voltage is supplied to the ripple filter (Q20), etc.
R5V	Receive 5 V converted from the S5V line at the R5 regulator circuit (Q25). The output voltage is supplied to the tripler (Q22), FM IF IC (IC9), IF amplifier (Q7), 1st mixer (Q6), RF amplifier (Q5), etc.
T5V	Transmit 5 V converted from the S5V line at the T5 regulator circuit (Q24). The output voltage is supplied to the APC amplifier (IC16), PA unit, etc.

• PLL CIRCUIT

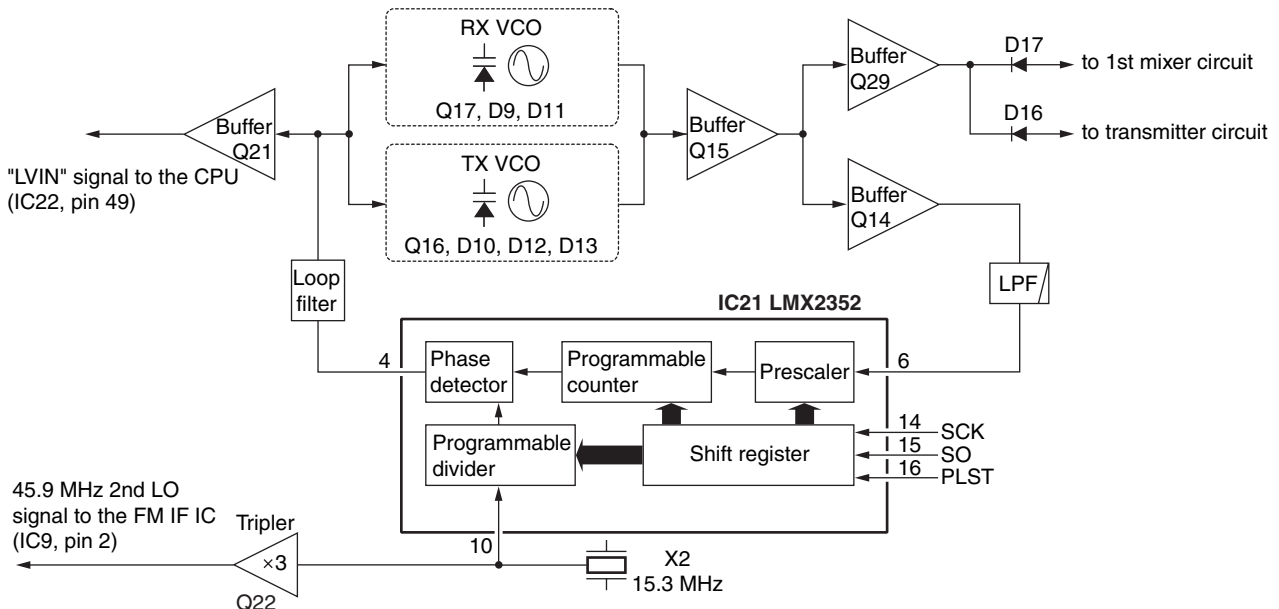

5-5 OTHER CIRCUITS

5-5-1 COMPANDER CIRCUIT (MAIN UNIT)

IC-F43GT/GS/F44GT/GS have compander circuit which can improve S/N ratio and become wide dynamic range. The circuit is composed in the base band IC (IC14).

(1) IN CASE OF TRANSMITTING

The audio signals from the microphone are applied to the base band IC (IC14, pin 3) via microphone amplifier (IC23). The signals are amplified at the amplifier section, and are then applied to the compressor circuit to compress the audio signals. The signals pass through (or bypass) scrambler section, and are then applied to the limiter section after being passed through the high-pass filter. The filtered signals pass through the splatter filter section, and are then applied to the modulation circuit (D12) via the FM/PM switch (IC13), low-pass filter (IC6) and D/A converter (IC12).

(2) IN CASE OF RECEIVING

The demodulated AF signals from the IF IC are applied to the amplifier section in base band IC (IC14, pin 23), and then pass through the low-pass and high-pass filter section to suppress unwanted signals. The filtered signals pass through (or bypass) scrambler section, and are then applied to the expander circuit to expand AF signals. The signals are applied to the base band IC's amplifier section (IC14, pins 19, 20), and are then applied to the AF amplifier circuit.

5-6 PORT ALLOCATIONS

5-6-1 D/A CONVERTOR IC (IC12)

Pin number	Port name	Description
10	BAL	Outputs the modulation balance level control signal. The signal is applied to the buffer amplifier (IC24, pin 1).
14	TLVA	Outputs the TX VCO lock voltage control signal.
15	RLVA	Outputs the RX VCO lock voltage control signal.
22	T1	Outputs the bandpass filter tuning signal. The output signal is applied to the bandpass filters (D19, D20, D24, D25).
23	T2	<ul style="list-style-type: none"> Outputs the bandpass filter tuning signal. The output signal is applied to the bandpass filters (D14, D15). Outputs the TX power control signal. The output signal is applied to the APC amplifier (IC16, pin 1).

• BASEBAND IC BLOCK DIAGRAM

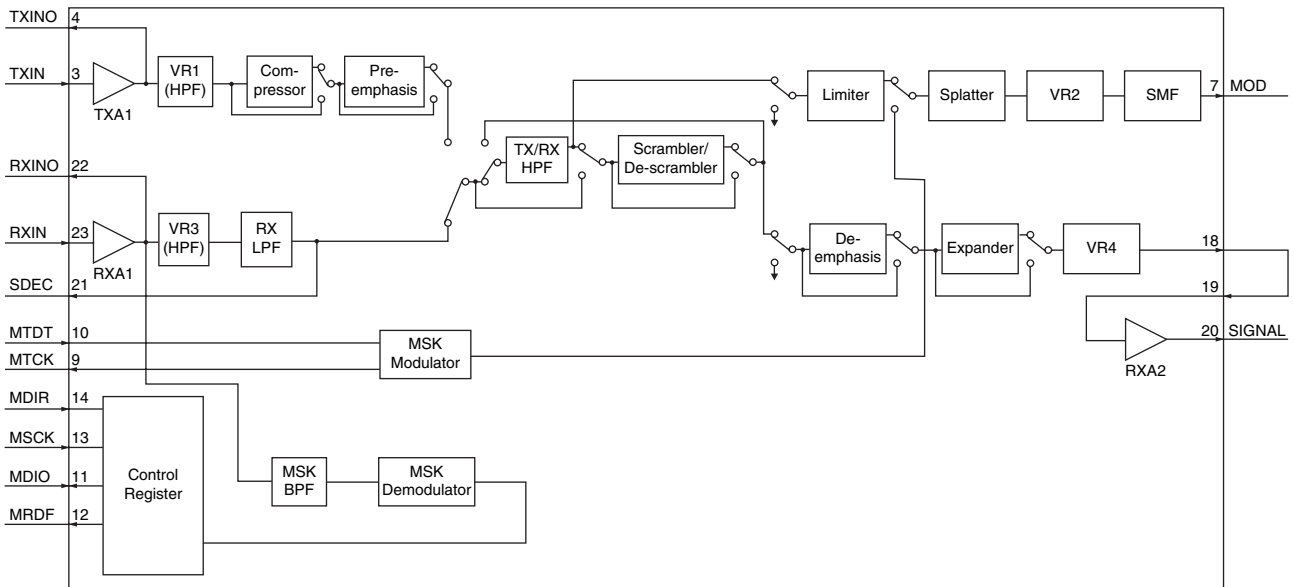

5-6-2 CPU (MAIN unit; IC22)

Pin number	Port name	Description
13, 15, 16	CENC0–CENC2	Output the CTCSS/DTCS signals.
29	REF	Outputs the reference oscillator correcting voltage. The voltage is applied to the buffer amplifier (IC24, pin3).
30	PLST	Outputs strobe signals to the PLL IC (IC21, pin 16).
34	PMFM	Outputs the FM/PM modulation switching signal to the FM/PM switch (IC13, pin 5). High: PM is selected.
35	MDIO	I/O port for the serial data signals from/to the base band IC (IC14, pin 11).
36	MSCK	Outputs clock signal to the base band IC (IC14, pin 13).
37	MDIR	Outputs serial data control signal to the base band IC (IC14, pin 14).
38	MTCK	Input port for the transmitting MSK clock signal from the base band IC (IC14, pin 9).
39	MTDT	Outputs MSK data for transmitting to the base band IC (IC14, pin 10).
40	MRDF	Input port for the receiving MSK detection signal from the base band IC (IC14, pin 12).
41	DAST	Outputs strobe signals to the D/A convertor (IC12, pin 6).
43	SENC	Output single tone encoder signal.
44	BEEP	Outputs beep audio signals.
45	SDEC	Input port for single tone decode signal from the base band IC (IC14, pin 21).
46	CDEC	Input port for CTCSS/DTCS signal from the amplifier (IC19, pin 1).
48	BATV	Input port for the detect signal for connecting battery pack's voltage.
49	LVIN	Input port for the PLL lock voltage.
50	RSSI	Input port for the S-meter signal from the FM IF IC (IC9, pin 12).
51	TEMP	Input port for the transceiver's internal temperature detecting signal.
69	CSFT	Outputs shift signal for reference oscillator's frequency.
70	AF	Outputs audio control signal. Low: Outputs audio signals from speaker.

Pin number	Port name	Description
74	PTT	Input port for the PTT switch detection signal. Low: While the PTT switch is pushed.
75	NOIS	Input port for the noise signal from the FM IF IC (IC9, pin 13).
76	SO	Outputs serial data to the PLL IC (IC21, pin 15) and D/A convertor (IC12, pin 8).
78	SCK	Outputs serial clock signal to the PLL IC (IC21 pin 14), D/A convertor (IC12, pin 7), etc.
79	CLI	Input port for the cloning data signal.
80	CLO	Outputs the cloning data signal.
82	ESDA	I/O port for data signals from/to the EEPROM (IC10, pin 5).
85	ESCL	Outputs clock signal to the EEPROM (IC10, pin 6).
86	S5C	Outputs the S5 regulator (Q26–Q28) control signal. Low: While the S5 regulator outputs 5 V voltage.
86	T5C	Outputs the T5 regulator (Q24) control signal. Low: While transmitting.
87	R5C	Outputs the R5 regulator (Q25) control signal. Low: While receiving.
88	TMUT	Outputs the transmitting mute switch control signal to the mute switch (D29). High: While muting.
90	ULCK	Input port for the PLL unlock signal. Low: The PLL circuit is unlocked.

SECTION 6 ADJUSTMENT PROCEDURE

6-1 PREPARATION

When adjusting IC-F43GT/F43GS/F44GT/F44GS, the optional CS-F33G ADJ ADJUSTMENT SOFTWARE (Rev. 1.0 or later), OPC-478 CLONING CABLE (RS-232C type), OPC-478U CLONING CABLE (USB type) and a JIG CABLE (see illustration at page 5-3) are required.

■ REQUIRED TEST EQUIPMENT

EQUIPMENT	GRADE AND RANGE	EQUIPMENT	GRADE AND RANGE
DC power supply	Output voltage : 7.2 V DC Current capacity : 5 A or more	Audio generator	Frequency range : 300–3000 Hz Output level : 1–500 mV
FM deviation meter	Frequency range : DC–800 MHz Measuring range : 0 to ±10 kHz	Attenuator	Power attenuation : 20 or 30 dB Capacity : 10 W or more
Frequency counter	Frequency range : 0.1–800 MHz Frequency accuracy : ±1 ppm or better Sensitivity : 100 mV or better	Standard signal generator (SSG)	Frequency range : 100–800 MHz Output level : 0.1 μV to 32 mV (–127 to –17 dBm)
Digital multimeter	Input impedance : 10 MΩ/V DC or better	DC voltmeter	Input impedance : 50 kΩ/V DC or better
RF power meter (terminated type)	Measuring range : 1–10 W Frequency range : 100–800 MHz Impedance : 50 Ω SWR : Better than 1.2 : 1	Oscilloscope	Frequency range : DC–20 MHz Measuring range : 0.01–20 V
		AC millivoltmeter	Measuring range : 10 mV–10 V

■ SYSTEM REQUIREMENTS

- Microsoft® Windows® 98/98SE/Me/2000
- RS-232C serial port (D-sub 9 pin)
- USB port

■ ADJUSTMENT SOFTWARE INSTALLATION

- ① Boot up Windows.
 - Quit all applications when Windows is running.
- ② Insert the cloning software CD into the appropriate CD drive.
- ③ Select 'Run' from the [Start] menu.
- ④ Type the setup program name using the full path name, then push [Enter] key.
(For example; D:\Setup.exe)
- ⑤ Follow the prompts.
- ⑥ Program group 'CS-F33G ADJ' appears in the 'Programs' folder of the [Start] menu.

■ BEFORE STARTING SOFTWARE ADJUSTMENT

Program the adjustment frequencies into the transceiver using with the CS-F33G before starting the software adjustment. Otherwise, the transceiver can not start software adjustment.

CAUTION! BACK UP the originally programmed memory data in the transceiver before programming the adjustment frequencies.

When program the adjustment frequencies into the transceiver, the transceiver's memory data will be overwritten and lose original memory data at the same time.

Microsoft and Windows are registered trademarks of Microsoft Corporation in the U.S.A. and other countries.

■ STARTING SOFTWARE ADJUSTMENT

- ① Connect the transceiver and PC with the OPC-478/U and JIG CABLE.
- ② Turn the transceiver power ON.
- ③ Boot up Windows, and click the program group 'CS-F33G ADJ' in the 'Programs' folder of the [Start] menu, then CS-F33G ADJ's window appears.
- ④ Click 'Connect' on the CS-F33G's window, then appears the transceiver's adjustment screen.
- ⑤ Set or modify adjustment data as desired.

• ADJUSTMENT FREQUENCY LIST

CH	FREQUENCY		ADJUSTMENT ITEM
	LOW BAND	HIGH BAND	
1	400.000 MHz	450.000 MHz	TX power : High Bandwidth : Wide
2	400.000 MHz	450.000 MHz	TX power : Low2 Bandwidth : Wide
3	400.000 MHz	450.000 MHz	TX power : Low Bandwidth : Wide
4	435.000 MHz	485.000 MHz	TX power : High Bandwidth : Narrow
5	435.000 MHz	485.000 MHz	TX power : High Bandwidth : Wide
6	435.000 MHz	485.000 MHz	TX power : High CTCSS : 151.4 Hz DTCS code: 007 Bandwidth : Wide
7	470.000 MHz	520.000 MHz	TX power : High Bandwidth : Wide
8	435.000 MHz	485.000 MHz	TX power : High Bandwidth : Middle

• CS-F33G ADJ'S SCREEN EXAMPLE

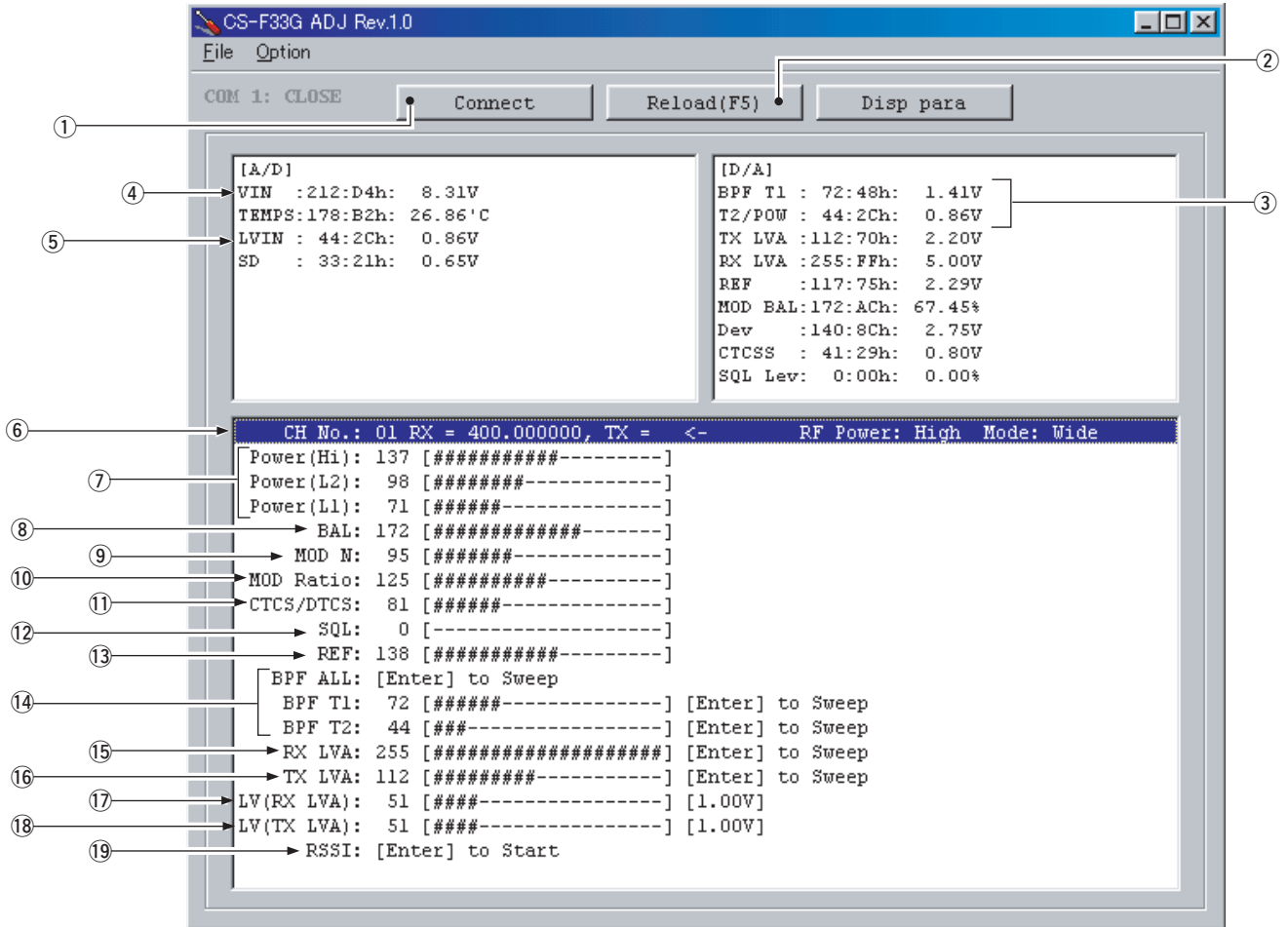

NOTE: The above values for settings are example only.
Each transceiver has its own specific values for each setting.

- | | |
|-------------------------------------|--|
| ①: Transceiver's connection state | ⑪: CTCSS/DTCS deviation |
| ②: Reload adjustment data | ⑫: Squelch level |
| ③: Receive sensitivity measurement | ⑬: Reference frequency |
| ④: Connected DC voltage measurement | ⑭: Receive sensitivity (automatic) |
| ⑤: PLL lock voltage measurement | ⑮: PLL lock voltage for RX (automatic) |
| ⑥: Operating channel select | ⑯: PLL lock voltage for TX (automatic) |
| ⑦: RF output power | ⑰: PLL lock voltage for RX (manual) |
| ⑧: FM modulation balance (Narrow) | ⑱: PLL lock voltage for TX (manual) |
| ⑨: FM deviation (Narrow) | ⑲: S-meter adjustment |
| ⑩: FM deviation (Wide/Middle) | |

• CONNECTION

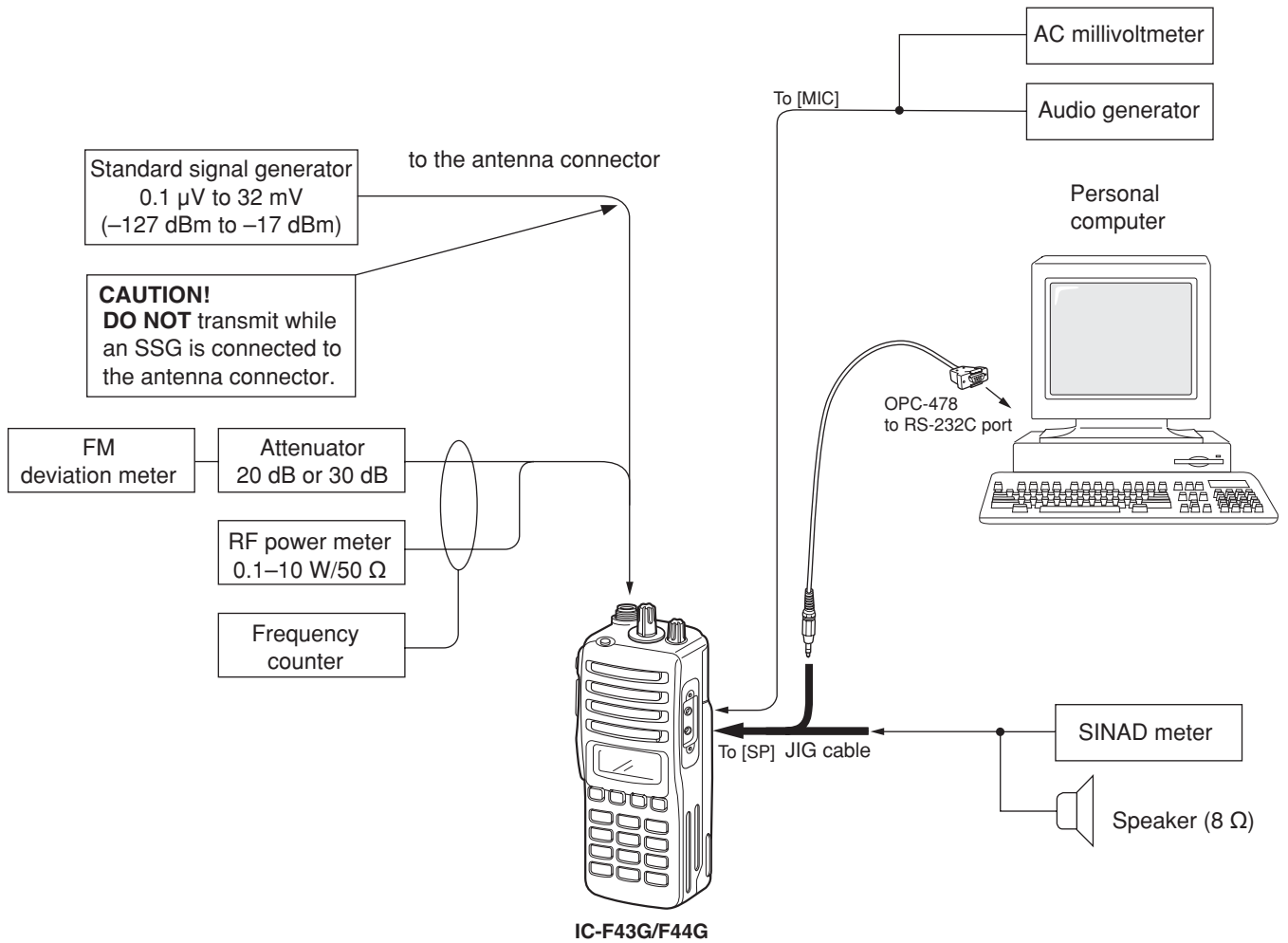

• JIG CABLE

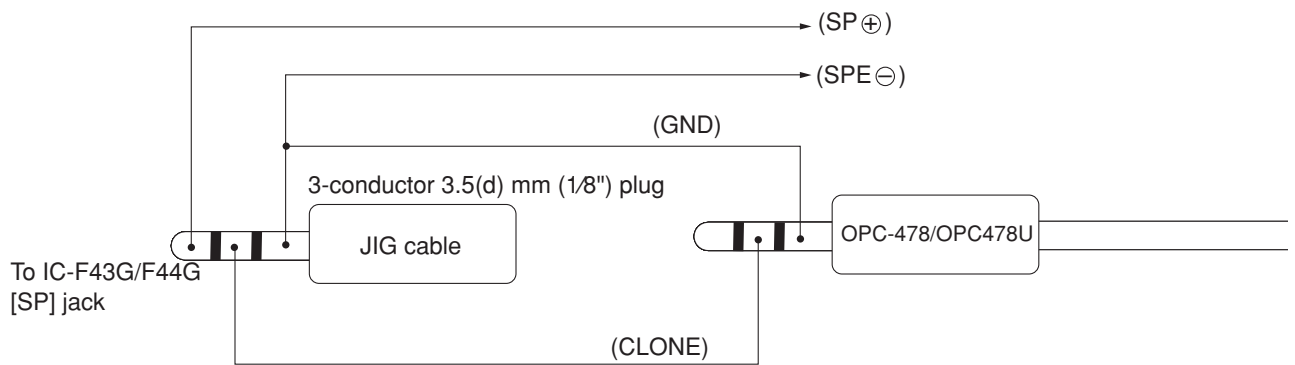

6-2 SOFTWARE ADJUSTMENT (TRANSMITTING)

Select an operation using [↑] / [↓] keys, then set specified value using [←] / [→] keys on the connected computer keyboard.

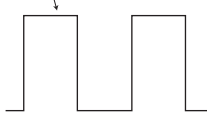
ADJUSTMENT	ADJUSTMENT CONDITION	MEASUREMENT		VALUE
		UNIT	LOCATION	
PLL LOCK VOLTAGE [LV(RX LVA)] [LV(TX LVA)]	1 • Operating CH : CH1 • Receiving	PC screen	Check the "LVIN" item on the CS-F33G ADJ's screen.	1.0 V
	2 • Operating CH : CH1 • Transmitting			1.0 V
	CONVENIENT: The PLL lock voltage can be adjusted automatically. Set the cursor to "RX LVA"/"TX LVA" and then push [ENTER] key.			
	3 • Operating CH : CH7 • Receiving	PC screen	Check the "LVIN" item on the CS-F33G ADJ's screen.	3.3–4.5 V (Verify)
4 • Operating CH : CH7 • Transmitting	3.3–4.5 V (Verify)			
REFERENCE FREQUENCY [REF]	1 • Operating CH : CH7 • Connect the RF power meter or 50 Ω dummy load to the antenna connector. • Transmitting	Top panel	Loosely couple the frequency counter to the antenna connector.	470.0000 MHz [L] 520.0000 MHz [H]
OUTPUT POWER [Power (Hi)]	1 • Operating CH : CH1 • Transmitting	Top panel	Connect the RF power meter to the antenna connector.	4.0 W
[Power (L2)]	2 • Operating CH : CH2 • Transmitting			2.0 W
[Power (L1)]	3 • Operating CH : CH3 • Transmitting			1.0 W
MODULATION BALANCE [BAL]	1 • Operating CH : CH4 • No audio applied to the [MIC] input. • Set an FM deviation meter as: HPF : OFF LPF : 20 kHz De-emphasis : OFF Detector : (P–P)/2 • IF bandwidth : Narrow • Push [P0] while transmitting	Top panel	Connect the FM deviation meter with the oscilloscope to the antenna connector through the attenuator.	Set to square wave form 
FM DEVIATION [MOD N] (Narrow)	1 • Operating CH : CH4 • Set the FM deviation meter as: HPF : OFF LPF : 20 kHz De-emphasis : OFF Detector : (P–P)/2 • Connect the audio generator to the [MIC] connector and set as : 1.0 kHz/150 mVrms • Transmitting	Top panel	Connect the FM deviation meter to the antenna connector through the attenuator.	±2.10 kHz
[MOD Ratio] (Wide)	2 • Operating CH : CH5 • Transmitting			±4.10 kHz
[MOD Ratio] (Middle)	3 • Operating CH : CH8 • Transmitting			±3.20 kHz (F44G only)
CTCSS/DTCS DEVIATION [CTCS/DTCS]	• Operating CH : CH6 • No audio applied to the [MIC] input. • Transmitting	Top panel	Connect the FM deviation meter to the antenna connector through the attenuator.	±0.70 kHz

SOFTWARE ADJUSTMENT (RECEIVING)

- Select an operation using [↑] / [↓] keys, then set specified value using [←] / [→] keys on the connected computer keyboard.
- Need to adjust “S-METER ADJUSTMENT” after “RX SENSITIVITY ADJUSTMENT” is adjusted. Otherwise, “S-METER ADJUSTMENT” will not be adjusted properly.

ADJUSTMENT	ADJUSTMENT CONDITION	MEASUREMENT		VALUE
		UNIT	LOCATION	
RX SENSITIVITY [BPF T1], [BPF T2]	1 <ul style="list-style-type: none"> • Operating CH : CH1 • Connect the standard signal generator to the antenna connector and set as: <ul style="list-style-type: none"> Frequency : 400.000 MHz [L] 450.000 MHz [H] Level : 10 μV* (-87 dBm) Modulation : 1 kHz Deviation : \pm3.5 kHz • Receiving 	Side panel	Connect the SINAD meter with an 8 Ω load to the [SP] jack through the JIG cable.	Minimum distortion level
	<p>CONVENIENT: The BPF T1, BPF T2 can be adjusted automatically.</p> <p>①-1: Set the cursor to “BPF ALL” on the CS-F33G ADJ's screen and then push [ENTER] key.</p> <p>①-2: The connected PC tunes BPF T1, BPF T2 to peak levels.</p> <p style="text-align: center;">or</p> <p>②-1: Set the cursor to one of BPF T1, T2 as desired.</p> <p>②-2: Push [ENTER] key to start tuning.</p> <p>②-3: Repeat ②-1 and ②-2 to perform additional BPF tuning.</p>			
S-METER [S-METER]	1 <ul style="list-style-type: none"> • Operating CH : CH1 • Connect the SSG to the antenna connector and set as: <ul style="list-style-type: none"> Frequency : 400.000 MHz [L] 450.000 MHz [H] Level : 14 μV* (-84 dBm) Modulation : 1 kHz Deviation : \pm3.5 kHz • Receiving 	Push the [ENTER] key on the connected computer's keyboard to set “L2 level”.		
	2 <ul style="list-style-type: none"> • Set the SSG as : <ul style="list-style-type: none"> Level : 0.45 μV* (-114 dBm) • Receiving 	Push the [ENTER] key on the connected computer keyboard to set “L0 level”.		
SQUELCH LEVEL [SQL]	1 <ul style="list-style-type: none"> • Operating CH : CH7 • Connect the SSG to the antenna connector and set as: <ul style="list-style-type: none"> Frequency : 470.000 MHz [L] 520.000 MHz [H] Level : 0.2 μV* (-121 dBm) Modulation : 1 kHz Deviation : \pm3.5 kHz • Receiving 	Side panel	Connect speaker to the [SP] jack through the JIG cable.	Set “SQL level” to close squelch. Then set “SQL level” at the point where the audio signals just appears.

*The output level of the standard signal generator (SSG) is indicated as the SSG's open circuit.

SECTION 7

PARTS LIST

[MAIN UNIT]

S.=Surface mount

REF NO.	ORDER NO.	DESCRIPTION	M.	H/V LOCATION
IC6	1110006350	S.IC LM2902PWR	B	55.4/23.8
IC8	1110005771	S.IC S-80942CNMC-G9CT2G	B	20.8/41.5
IC9	1110003201	S.IC TA31136FNG (EL)	T	81.5/17
IC10	1130011581	S.IC 24LC64T-I/5N G	B	29.7/13.2
IC12	1190001350	S.IC M62364FP 600D	B	38.9/26.2
IC13	1130006221	S.IC TC4W53FU (TE12L,F)	B	47.1/24
IC14	1110006221	S.IC AK2346P-E2/P	B	41.5/13.2
IC15	1110001811	S.IC TA7368FG (5,ER)	T	97.3/15.4
IC16	1110002751	S.IC TA75S01F (TE85R,F)	T	88.1/12.4
IC17	1110005350	S.IC NJM2870F05-TE1-#FZZB	B	93.2/20.2
IC19	1110006380	S.IC LM2904PWR	B	42.9/39.6
IC20	1130009090	S.IC LC75834W-TLM-E	T	57.3/20.3
IC21	1130010100	S.IC LMX2352TMX/NOPB	T	79.5/33.7
IC22	1140011511	S.IC HD64F2238BTF13V	B	17.4/22.4
IC23	1110006380	S.IC LM2904PWR	B	36.9/39.3
IC24	1110002751	S.IC TA75S01F (TE85R,F)	B	56.2/36.9
IC25	1130007021	S.IC TC7S66FU (TE85L,F)	B	58.2/33
Q2	1590003321	S.FET TPC6103 (TE85L,F)	T	98.4/4.8
Q3	1590003290	S.STR UNR9213J-(TX)	T	93.4/5
Q4	1560000841	S.FET 2SK1829 (TE85R,F)	T	90.9/34.7
Q5	1580000731	S.FET 3SK293 (TE85L,F)	B	90.9/39
Q6	1580000760	S.FET 3SK299-T1 U73	B	86.8/29.5
Q7	1530002601	S.STR 2SC4215-O (TE85R,F)	B	89.2/19.7
Q14	1530003260	S.STR 2SC5006-T1	B	79.9/31.5
Q15	1530003260	S.STR 2SC5006-T1	B	73.2/29.9
Q16	1530002920	S.STR 2SC4226-T1 R25	B	75.7/25.5
Q17	1530002920	S.STR 2SC4226-T1 R25	B	74.7/32.3
Q18	1590001400	S.STR XP1214 (TX)	T	71.3/32.1
Q19	1590003290	S.STR UNR9213J-(TX)	T	71.4/29.7
Q20	1530002851	S.STR 2SC4116-BL (TE85R,F)	T	86.5/25.8
Q21	1560000541	S.FET 2SK880-Y (T5RICOM,F)	T	75/23.1
Q22	1530002851	S.STR 2SC4116-BL (TE85R,F)	T	80.9/24.7
Q24	1510000920	S.STR 2SA1577 T106 Q	B	63.3/14.3
Q25	1510000920	S.STR 2SA1577 T106 Q	B	64.4/10.4
Q26	1520000450	S.STR 2SB1132 T100 Q	B	56.6/11.3
Q27	1590001190	S.STR XP6501-(TX).AB	B	57.5/7.3
Q28	1590003230	S.STR UNR9113J-(TX)	B	54.1/7.1
Q29	1530003260	S.STR 2SC5006-T1	B	78.2/25.9
Q38	1590003290	S.STR UNR9213J-(TX)	B	81.8/39.2
Q40	1590003290	S.STR UNR9213J-(TX)	B	49.5/18.4
Q41	1590001190	S.STR XP6501-(TX).AB	T	90.8/21.3
Q42	1520000450	S.STR 2SB1132 T100 Q	T	89.3/17.2
Q43	1590003400	S.STR UNR9112J	T	77.7/4.9
Q44	1590003270	S.STR UNR9210J-(TX)	B	29.8/5.6
Q45	1590003230	S.STR UNR9113J-(TX)	T	54.6/4.5
Q46	1590003290	S.STR UNR9213J-(TX)	T	84.9/10.5
Q502	1560001360	S.FET 2SK3019 TL	B	35.9/11.7
Q503	1590003290	S.STR UNR9213J-(TX)	T	81.6/42.6
D5	1160000060	S.DIO DAN202U T106	T	93.6/7.3
D6	1790001260	S.DIO MA25077-(TX)	B	27.6/31
D8	1790001250	S.DIO MA25111-(TX)	T	86.8/28.9
D9	1750000711	S.VCP HVC350BTRF-E	B	68.6/29.7
D10	1750000711	S.VCP HVC350BTRF-E	B	70.1/27.9
D11	1750000711	S.VCP HVC350BTRF-E	B	68.4/32.3
D12	1720000570	S.VCP MA368 (TX)	B	68.4/26.7
D13	1750000711	S.VCP HVC350BTRF-E	B	71.3/25.9
D14	1750000711	S.VCP HVC350BTRF-E	B	85.1/35.5
D15	1750000711	S.VCP HVC350BTRF-E	B	87.2/41.5
D16	1750000581	S.DIO 1SV307 (TPH3,F)	B	84.2/18.1
D17	1790001260	S.DIO MA25077-(TX)	B	83.4/22.2
D18	1790001250	S.DIO MA25111-(TX)	T	92.9/36.6
D19	1750000711	S.VCP HVC350BTRF-E	B	94.1/41.6
D20	1750000711	S.VCP HVC350BTRF-E	B	92.8/41.6
D21	1160000060	S.DIO DAN202U T106	B	28.4/22.6
D23	1750000940	S.DIO ISS400 TE61	B	28/24.5
D24	1750000711	S.VCP HVC350BTRF-E	B	96.7/39.2
D25	1750000711	S.VCP HVC350BTRF-E	B	95.4/39.2
D28	1790001670	S.DIO RB706F-40T106	B	29.8/2.9
F11	2030000150	S.MLH FL-335 (46.350 MHz)	T	91.3/27.1
F12	2020001530	CER CFWL8450KFFFA-B0		
X1	6070000191	S.DCR CDBKB450KCA24-R0	B	80/16.9
X2	6050011931	S.XTL CR-781A (15.3 MHz)	B	63.3/38.3
X5	6050011730	S.XTL CR-765 (3.6864 MHz)	B	38.3/4
X6	6050011830	S.XTL CR-774 (12.288 MHz)	B	30.9/31.5
L7	6200007690	S.COL LQW2BHN18NJ03L ④, ⑥, ⑧, ⑩, ⑫, ⑮, ⑱	B	98.3/37.2
	6200007700	S.COL LQW2BHN22NJ03L except ④, ⑥, ⑧, ⑩, ⑫, ⑮, ⑱	B	98.3/37.2
L8	6200007690	S.COL LQW2BHN18NJ03L ④, ⑥, ⑧, ⑩, ⑫, ⑮, ⑱	B	93.7/37
	6200007700	S.COL LQW2BHN22NJ03L except ④, ⑥, ⑧, ⑩, ⑫, ⑮, ⑱	B	93.7/37
L8	6200007710	S.COL LQW2BHN27NJ03L	B	93.7/37
L9	6200007680	S.COL LQW2BHN12NJ03L	B	87.7/38.2
L11	6200007680	S.COL LQW2BHN12NJ03L	B	85.9/33.8
L12	6200007881	S.COL ELJRF 33NJFB ②, ⑫ only	B	84.9/28
	6200007921	S.COL ELJRF 15NJFB ①, ⑨, ⑪, ⑳ only	B	84.9/28
L13	6200005510	S.COL ELJRD R27J-F	B	89.4/33.2

[MAIN UNIT]

M.=T: Mounted on the Top side, B: Mounted on the Bottom side

REF NO.	ORDER NO.	DESCRIPTION	M.	H/V LOCATION
L21	6200007921	S.COL ELJRF 15NJFB	B	80.1/24
L22	6200007901	S.COL ELJRF 22NJFB	B	75.1/30.2
L25	6200008490	S.COL 0.30-0.9-3TR 7.5N	B	71.4/22.8
L27	6200004951	S.COL NLV25T-1R8J	T	70.5/24.4
L28	6200012640	S.COL ELJFC R82MH	T	69/27.7
L31	6200007720	S.COL LQW2BHN33NJ03L	B	100.9/35.9
L32	6200007911	S.COL ELJRF 18NJFB	B	78.3/32.9
L33	6200004480	S.COL MLF1608D R82K-T	T	81.1/22.5
L35	6200003540	S.COL MLF1608D R22K-T	T	84.6/25.5
L37	6200012400	S.COL 0.30-0.91-4TL 8.6N	B	70.6/34.1
L41	6200007881	S.COL ELJRF 33NJFB	B	80.5/29.7
L42	6200005461	S.COL LL1608-FSL82NJ	T	68.4/30.7
L43	6200003550	S.COL MLF1608A 4R7K-T ①, ②, ③, ⑤, ⑥, ⑦, ⑩, ⑫, ⑮, ⑰, ⑲, ⑳	T	73.1/24.7
	6200004660	S.COL MLF1608A 1R8K-T ③, ④, ⑤, ⑥, ⑦, ⑬, ⑭, ⑮, ⑯, ⑰	T	73.1/24.7
L46	6200007561	S.COL LL1608-FHL15NJ ②, ⑫	T	86.3/25
	6200007580	S.COL LL1608-FH22NJ ④, ⑥, ⑧, ⑯, ⑰, ⑱	B	86.3/25
	6200007581	S.COL LL1608-FHL22NJ ⑧	B	86.3/25
	6200007590	S.COL LL1608-FH27NJ ③, ⑤, ⑦, ⑩, ⑬, ⑮, ⑰, ⑲	B	86.3/25
	6200007591	S.COL LL1608-FHL27NJ ⑨	B	86.3/25
	6200009280	S.COL LQW18AN27NG00D ①, ⑪, ⑳	B	86.3/25
L47	6200002790	S.COL ELJFC R82M-F	T	71.2/34.5
L48	6200002851	S.COL NLV25T-R82J	T	74.3/28.4
L49	6200007890	S.COL ELJRF 27NJF2 (27) ④, ⑤, ⑥, ⑦, ⑩, ⑫, ⑮, ⑰, ⑲, ⑳ only	B	77.8/27.9
	6200007891	S.COL ELJRF 27NJFB ①, ②, ③, ⑤, ⑥, ⑦, ⑩, ⑫, ⑰, ⑲ only	B	77.8/27.9
R1	7030004970	S.RES ERJ2GEJ 470 X (47)	T	87.4/14.6
R4	7030008280	S.RES ERJ2GEJ 271 X (270) except ③, ⑤, ⑬, ⑮	T	87.5/7.8
	7030008370	S.RES ERJ2GEJ 561 X (560) ③, ⑤, ⑬, ⑮	T	87.5/7.8
R5	7030005070	S.RES ERJ2GEJ 683 X (68 k)	T	86.2/8.6
R6	7030005110	S.RES ERJ2GEJ 224 X (220 k) except ③, ⑤, ⑬, ⑮	T	86/15.7
	7030008300	S.RES ERJ2GEJ 184 X (180 k) ③, ⑤, ⑬, ⑮	T	86/15.7
R7	7030005080	S.RES ERJ2GEJ 823 X (82 k) ①, ②, ⑤, ⑦, ⑨, ⑩, ⑫, ⑮, ⑰, ⑲, ⑳	T	85.5/13.4
	7030005310	S.RES ERJ2GEJ 124 X (120 k) ③, ④, ⑥, ⑧, ⑬, ⑭, ⑰, ⑱	T	85.5/13.4
R8	7030005110	S.RES ERJ2GEJ 224 X (220 k) except ③, ⑤, ⑬, ⑮	T	88/10.2
	7030005170	S.RES ERJ2GEJ 474 X (470 k) ③, ⑤, ⑬, ⑮	T	88/10.2
R9	7030008280	S.RES ERJ2GEJ 271 X (270)	T	90.5/12.3
R12	7030005530	S.RES ERJ2GEJ 100 X (10)	B	90.2/36.8
R13	7030005090	S.RES ERJ2GEJ 104 X (100 k)	B	92.8/39.5
R14	7030005720	S.RES ERJ2GEJ 563 X (56 k)	T	93/40.1
R15	7030005240	S.RES ERJ2GEJ 473 X (47 k)	T	91.6/38.9
R16	7030004980	S.RES ERJ2GEJ 101 X (100)	B	89.6/41.2
R17	7030004970	S.RES ERJ2GEJ 470 X (47)	T	89.1/37.7
R18	7030005040	S.RES ERJ2GEJ 472 X (4.7 k)	T	77.2/28.8
R19	7030005080	S.RES ERJ2GEJ 823 X (82 k)	T	91.1/37.6
R21	7030005110	S.RES ERJ2GEJ 224 X (220 k)	T	87.6/38.7
R22	7030005050	S.RES ERJ2GEJ 103 X (10 k)	T	88.6/38.9
R23	7030005110	S.RES ERJ2GEJ 224 X (220 k)	T	86.5/35.6
R24	7030005050	S.RES ERJ2GEJ 103 X (10 k)	B	86.2/22.9
R25	7030005040	S.RES ERJ2GEJ 472 X (4.7 k)	B	85.7/31.2
R29	7030007270	S.RES ERJ2GEJ 151 X (150)	B	89.2/27.5
R31	7030004980	S.RES ERJ2GEJ 101 X (100)	T	89.2/33.8
R32	7030010040	S.RES ERJ2GEJ-JPW	T	92.2/31.9
R33	7030007270	S.RES ERJ2GEJ 151 X (150)	B	90.2/22.9
R34	7030005110	S.RES ERJ2GEJ 224 X (220 k)	B	88.6/21.6
R35	7030004980	S.RES ERJ2GEJ 101 X (100)	B	87.2/21.2
R36	7030005030	S.RES ERJ2GEJ 152 X (1.5 k)	B	81.9/12.6
R38	7030005090	S.RES ERJ2GEJ 104 X (100 k)	T	81.8/12.2
R39	7030004970	S.RES ERJ2GEJ 470 X (47)	B	81.4/11.6
R40	7030007270	S.RES ERJ2GEJ 151 X (150)	T	81.8/21.3
R43	7030004970	S.RES ERJ2GEJ 470 X (47)	T	77.8/14.1
R44	7030005240	S.RES ERJ2GEJ 473 X (47 k)	T	77.9/21.3
R45	7030008290	S.RES ERJ2GEJ 183 X (18 k)	T	77.2/17.4
R46	7030005000	S.RES ERJ2GEJ 471 X (470)	T	76.2/20.7
R48	7030005000	S.RES ERJ2GEJ 471 X (470)	B	87.2/19.9
R50	7030004990	S.RES ERJ2GEJ 221 X (220)	B	84.9/22.8
R68	7030005050	S.RES ERJ2GEJ 103 X (10 k)	B	84.7/15.9
R69	7030005040	S.RES ERJ2GEJ 472 X (4.7 k)	B	85.6/18.2
R70	7030005530	S.RES ERJ2GEJ 100 X (10)	B	80.2/24.9
R71	7030005600	S.RES ERJ2GEJ 273 X (27 k)	B	78.1/23.9
R72	7030005240	S.RES ERJ2GEJ 473 X (47 k)	B	35.5/34.2
R73	7030008010	S.RES ERJ2GEJ 123 X (12 k)	B	39.1/19.5
R74	7030006610	S.RES ERJ2GEJ 394 X (390 k)	B	40.1/19.5
R75	7030005100	S.RES ERJ2GEJ 154 X (150 k)	B	78.7/29.5
R76	7030004980	S.RES ERJ2GEJ 101 X (100)	B	78.8/27.9
R77	7030004980	S.RES ERJ2GEJ 101 X (100)	B	76.6/29.2
R78	7030005090	S.RES ERJ2GEJ 104 X (100 k)	B	75/29.2
R79	7030006020	S.RES RR0510P-682-D (6.8 k)	B	75.5/34.3
R80	7030005050	S.RES ERJ2GEJ 103 X (10 k)	T	74.4/30.6
R81	7030005090	S.RES ERJ2GEJ 104 X (100 k)	B	47.9/20.8
R82	7030010040	S.RES ERJ2GEJ-JPW	B	74.3/23.5
R83	7030006020	S.RES RR0510P-682-D (6.8 k)	B	74.3/22.5
R84	7030006020	S.RES RR0510P-682-D (6.8 k)	B	72.8/24.9
R85	7030006020	S.RES RR0510P-682-D (6.8 k)	B	72.2/34.3
R86	7030005110	S.RES ERJ2GEJ 224 X (220 k)	T	68.8/21.8

①: GT [MTG-01] ②: GT [MTE-01] ③: GT [USA-01] ④: GT [USA-02] ⑤: GT [GEN-01]
⑥: GT [GEN-02] ⑦: GT [EUR-01] ⑧: GT [AUS-02] ⑨: GT [CHN-01] ⑩: GT [USA-04]

⑪: GS [MTG-01] ⑫: GS [MTE-01] ⑬: GS [USA-01] ⑭: GS [USA-02] ⑮: GS [GEN-01]
⑯: GS [GEN-02] ⑰: GS [EUR-01] ⑱: GS [AUS-02] ⑲: GS [USA-04] ⑳: GS [CHN-01]

[MAIN UNIT]

S.=Surface mount

REF NO.	ORDER NO.	DESCRIPTION	M.	H/V LOCATION
R87	7030005000	S.RES ERJ2GEJ 471 X (470)	T	69/34.6
R88	7030009270	S.RES ERJ2GEJ 821 X (820)	T	73.1/30.9
R89	7030005050	S.RES ERJ2GEJ 103 X (10 k)	T	74.2/25.2
R90	7030005170	S.RES ERJ2GEJ 474 X (470 k)	T	71.1/21
R91	7030005240	S.RES ERJ2GEJ 473 X (47 k)	T	70.8/19.7
R92	7030005310	S.RES ERJ2GEJ 124 X (120 k)	T	72.4/21.5
R93	7030005060	S.RES ERJ2GEJ 333 X (33 k)	B	46.2/20.8
R95	7030005030	S.RES ERJ2GEJ 152 X (1.5 k)	T	76.2/28.8
R96	7030005240	S.RES ERJ2GEJ 473 X (47 k)	B	87.3/36.5
R97	7030005120	S.RES ERJ2GEJ 102 X (1 k)	B	11.6/29.9
R98	7030007290	S.RES ERJ2GEJ 222 X (2.2 k)	T	86.4/27.7
R100	7030005040	S.RES ERJ2GEJ 472 X (4.7 k)	T	73.6/20.3
R101	7030004990	S.RES ERJ2GEJ 221 X (220)	T	75.1/25.9
R103	7030005110	S.RES ERJ2GEJ 224 X (220 k)	B	56.6/40.1
R104	7030005090	S.RES ERJ2GEJ 104 X (100 k)	B	55/39.1
R106	7030005160	S.RES ERJ2GEJ 105 X (1 M)	B	43.5/7.9
R107	7030005060	S.RES ERJ2GEJ 333 X (33 k)	B	37.5/7.7
R108	7030005000	S.RES ERJ2GEJ 471 X (47 k)	B	64/35.4
R110	7030005090	S.RES ERJ2GEJ 104 X (100 k)	T	70.7/16.9
R111	7030005170	S.RES ERJ2GEJ 474 X (470 k)	T	66.9/32.4
R114	7030005080	S.RES ERJ2GEJ 823 X (82 k)	B	38.9/7.3
R115	7030007570	S.RES ERJ2GEJ 122 X (1.2 k)	T	85.5/23.4
R116	7030007060	S.RES ERJ2GEJ 684X (680 k)	T	83.2/26.3
R117	7030005160	S.RES ERJ2GEJ 105 X (1 M)	B	40.6/7.2
R118	7030005110	S.RES ERJ2GEJ 224 X (220 k)	B	26.9/6.4
R119	7030005240	S.RES ERJ2GEJ 473 X (47 k)	B	36.5/7.7
R120	7030005240	S.RES ERJ2GEJ 473 X (47 k)	B	41.6/19.9
R121	7030005110	S.RES ERJ2GEJ 224 X (220 k)	B	36.4/44.6
R122	7030005070	S.RES ERJ2GEJ 683 X (68 k)	B	35/43.1
R123	7030005060	S.RES ERJ2GEJ 333 X (33 k)	B	70.3/41.9
R124	7030005170	S.RES ERJ2GEJ 474 X (470 k)	T	71.4/22.3
R127	7030005090	S.RES ERJ2GEJ 104 X (100 k)	T	70/20.6
R130	7030007300	S.RES ERJ2GEJ 332 X (3.3 k)	T	99.4/35.2
R131	7030005050	S.RES ERJ2GEJ 103 X (10 k)	B	101.3/41.5
R147	7030005090	S.RES ERJ2GEJ 104 X (100 k)	B	55.2/29.8
R148	7030005070	S.RES ERJ2GEJ 683 X (68 k)	B	55.2/30.8
R151	7030005240	S.RES ERJ2GEJ 473 X (47 k)	B	49.8/25.5
R152	7030005230	S.RES ERJ2GEJ 334 X (330 k)	B	52.1/24.4
	7030005700	S.RES ERJ2GEJ 274 X (270 k) except ③, ⑬	B	52.1/24.4
R154	7030005310	S.RES ERJ2GEJ 124 X (120 k)	B	53.6/29.9
R156	7030010040	S.RES ERJ2GEJ-JPW	B	54.8/28.5
R157	7030005050	S.RES ERJ2GEJ 103 X (10 k)	B	53.6/29.9
R161	7030005050	S.RES ERJ2GEJ 103 X (10 k)	B	61.4/14.4
R162	7030005040	S.RES ERJ2GEJ 472 X (4.7 k)	B	60.1/12.9
R163	7030005050	S.RES ERJ2GEJ 103 X (10 k)	B	62.5/11.4
R164	7030005040	S.RES ERJ2GEJ 472 X (4.7 k)	B	62.1/10.1
R165	7030005050	S.RES ERJ2GEJ 103 X (10 k)	B	55.5/8.2
R166	7030007290	S.RES ERJ2GEJ 222 X (2.2 k)	B	58/5.3
R172	7030005050	S.RES ERJ2GEJ 103 X (10 k)	T	89.1/35.9
R173	7030008400	S.RES ERJ2GEJ 182 X (1.8 k)	T	91.1/36.6
R174	7030005170	S.RES ERJ2GEJ 474 X (470 k)	T	92.9/34.4
R175	7030005110	S.RES ERJ2GEJ 224 X (220 k)	T	92.4/32.9
R181	7030005220	S.RES ERJ2GEJ 223 X (22 k)	B	40/34.9
R182	7030005220	S.RES ERJ2GEJ 223 X (22 k)	B	39.4/41.3
R183	7030005220	S.RES ERJ2GEJ 223 X (22 k)	B	40.4/41.3
R184	7030005090	S.RES ERJ2GEJ 104 X (100 k) ③, ④, ⑤, ⑥, ⑦, ⑬, ⑭, ⑮, ⑯, ⑰	B	43.8/33.3
	7030007300	S.RES ERJ2GEJ 332 X (3.3 k) ①, ②, ⑧, ⑨, ⑩, ⑪, ⑫, ⑱, ⑲, ⑳	B	43.8/33.3
R185	7030005170	S.RES ERJ2GEJ 474 X (470 k) ③, ④, ⑤, ⑥, ⑦, ⑬, ⑭, ⑮, ⑯, ⑰	B	43.8/35.3
	7030005290	S.RES ERJ2GEJ 682 X (6.8 k) ①, ②, ⑧, ⑨, ⑩, ⑪, ⑫, ⑱, ⑲, ⑳	B	43.8/35.3
R186	7030005000	S.RES ERJ2GEJ 471 X (470)	B	45.5/39.7
R203	7030005110	S.RES ERJ2GEJ 224 X (220 k)	B	12.2/5.5
R204	7030005090	S.RES ERJ2GEJ 104 X (100 k)	B	12.3/6.3
R205	7030005090	S.RES ERJ2GEJ 104 X (100 k)	B	28/19.3
R209	7030005240	S.RES ERJ2GEJ 473 X (47 k)	B	51.2/17.8
R210	7030005240	S.RES ERJ2GEJ 473 X (47 k)	B	51.2/19.5
R211	7030005240	S.RES ERJ2GEJ 473 X (47 k)	B	53.6/18.7
R213	7030005040	S.RES ERJ2GEJ 472 X (4.7 k)	B	51.8/20.8
R214	7030005240	S.RES ERJ2GEJ 473 X (47 k)	B	50.2/20.6
R215	7030005070	S.RES ERJ2GEJ 683 X (68 k)	B	59/20.7
R216	7030005070	S.RES ERJ2GEJ 683 X (68 k)	B	59/22.8
R217	7030005070	S.RES ERJ2GEJ 683 X (68 k)	B	59/24.7
R218	7030005070	S.RES ERJ2GEJ 683 X (68 k)	B	59/25.6
R219	7030007350	S.RES ERJ2GEJ 393 X (39 k)	B	59/26.5
R220	7030005220	S.RES ERJ2GEJ 223 X (22 k)	B	58.3/29.6
R221	7030005220	S.RES ERJ2GEJ 223 X (22 k)	B	5.7/13.8
R222	7030008300	S.RES ERJ2GEJ 184 X (180 k)	B	7.8/15.6
R223	7030005720	S.RES ERJ2GEJ 563 X (56 k)	B	6.8/15.4
R224	7030005220	S.RES ERJ2GEJ 223 X (22 k)	B	5.8/15.4
R225	7030007260	S.RES ERJ2GEJ 330 X (33 k)	T	101.4/18.8
R226	7030005530	S.RES ERJ2GEJ 100 X (10)	T	94.5/18.8
R227	7030009140	S.RES ERJ2GEJ 272 X (2.7 k)	T	89/20.8
R228	7030007300	S.RES ERJ2GEJ 332 X (3.3 k)	T	88.6/22.3
R229	7030005120	S.RES ERJ2GEJ 102 X (1 k)	T	92.9/22.1
R231	7030005100	S.RES ERJ2GEJ 154 X (150 k)	B	30.4/22.6
R233	7030004980	S.RES ERJ2GEJ 101 X (100)	T	98.4/10.3
R234	7030005530	S.RES ERJ2GEJ 100 X (10)	T	100.7/12.4
R235	7030005000	S.RES ERJ2GEJ 471 X (470)	T	83.5/5
R236	7030005090	S.RES ERJ2GEJ 104 X (100 k)	T	75.7/4.3
R237	7030005530	S.RES ERJ2GEJ 100 X (10)	B	23.8/14
R238	7030005000	S.RES ERJ2GEJ 471 X (470)	B	83/8.4
R239	7030007340	S.RES ERJ2GEJ 153 X (15 k)	B	27.9/6.4
R240	7030005210	S.RES ERJ2GEJ 822 X (8.2 k)	B	35.2/32.9
R241	7030005110	S.RES ERJ2GEJ 224 X (220 k)	B	40/31.9
R242	7030005230	S.RES ERJ2GEJ 334 X (330 k)	B	35.2/31.9
R243	7030005040	S.RES ERJ2GEJ 472 X (4.7 k)	B	38.6/32.4
R244	7030005210	S.RES ERJ2GEJ 822 X (8.2 k)	B	40/33.9
R245	7030005070	S.RES ERJ2GEJ 683 X (68 k)	B	40/35.9
R246	7030008290	S.RES ERJ2GEJ 183 X (18 k)	T	98.5/8.1
R247	7030005000	S.RES ERJ2GEJ 471 X (470)	B	36.6/20.7

①: GT [MTG-01] ②: GT [MTE-01] ③: GT [USA-01] ④: GT [USA-02] ⑤: GT [GEN-01] ⑥: GT [GEN-02] ⑦: GT [EUR-01] ⑧: GT [AUS-02] ⑨: GT [CHN-01] ⑩: GT [USA-04]

[MAIN UNIT]

M.=T: Mounted on the Top side, B: Mounted on the Bottom side

REF NO.	ORDER NO.	DESCRIPTION	M.	H/V LOCATION
R256	7510001730	S.TMR ERTJOEP 473J	B	20/32.9
R257	7030005090	S.RES ERJ2GEJ 104 X (100 k)	B	19/33.9
R258	7030005530	S.RES ERJ2GEJ 100 X (10)	B	24.9/28.8
R259	7030005160	S.RES ERJ2GEJ 105 X (1 M)	B	27.7/27.8
R260	7030008010	S.RES ERJ2GEJ 123 X (12 k)	B	27.3/29.3
R261	7030008010	S.RES ERJ2GEJ 123 X (12 k)	B	26/30.5
R262	7030008010	S.RES ERJ2GEJ 123 X (12 k)	B	27.3/34
R263	7030005090	S.RES ERJ2GEJ 104 X (100 k)	B	22.9/32.9
R264	7030006010	S.RES RR0510P-472-D (4.7 k)	B	15.3/33.7
R265	7030006010	S.RES RR0510P-472-D (4.7 k)	B	14.8/32.7
R266	7030005090	S.RES ERJ2GEJ 104 X (100 k)	B	45/18.5
R267	7030005090	S.RES ERJ2GEJ 104 X (100 k)	B	44/18.5
R269	7030005090	S.RES ERJ2GEJ 104 X (100 k)	B	46/18.5
R270	7030007290	S.RES ERJ2GEJ 222 X (2.2 k)	B	19.9/31.9
R272	7030004980	S.RES ERJ2GEJ 101 X (100)	T	56.3/4.4
R273	7030010040	S.RES ERJ2GEJ-JPW	B	15.6/5.3
R275	7030005110	S.RES ERJ2GEJ 224 X (220 k)	B	14.4/5.3
R281	7030005720	S.RES ERJ2GEJ 563 X (56 k)	T	95/37.6
R282	7030005090	S.RES ERJ2GEJ 104 X (100 k)	B	34.4/39.5
R283	7030005090	S.RES ERJ2GEJ 104 X (100 k)	B	34.4/37.9
R288	7030005040	S.RES ERJ2GEJ 472 X (4.7 k)	B	13.7/4.4
R289	7030005090	S.RES ERJ2GEJ 104 X (100 k)	B	38.4/33.6
R291	7030005120	S.RES ERJ2GEJ 102 X (1 k)	B	9.5/14.7
R292	7030005090	S.RES ERJ2GEJ 104 X (100 k)	B	29.8/18
R293	7030005050	S.RES ERJ2GEJ 103 X (10 k)	B	28.3/18
R295	7030005240	S.RES ERJ2GEJ 473 X (47 k)	T	62.1/14.1
R300	7030005090	S.RES ERJ2GEJ 104 X (100 k)	T	61.7/16.4
R301	7030005070	S.RES ERJ2GEJ 683 X (68 k)	B	47.9/27.4
R302	7030005090	S.RES ERJ2GEJ 104 X (100 k)	B	95.4/37.1
R303	7030005050	S.RES ERJ2GEJ 103 X (10 k)	T	95.5/40.6
R304	7030010040	S.RES ERJ2GEJ-JPW	B	72.4/31.8
R305	7030005090	S.RES ERJ2GEJ 104 X (100 k) ③, ④, ⑤, ⑥, ⑦, ⑬, ⑭, ⑮, ⑯, ⑰	T	66.9/33.4
	7030008300	S.RES ERJ2GEJ 184 X (180 k) ①, ②, ⑧, ⑨, ⑩, ⑪, ⑫, ⑱, ⑲, ⑳	T	66.9/33.4
R306	7030005530	S.RES ERJ2GEJ 100 X (10)	B	68.6/24.5
R307	7030005580	S.RES ERJ2GEJ 560 X (56)	B	79.4/34.4
R308	7030005050	S.RES ERJ2GEJ 103 X (10 k) ④, ⑧, ⑬, ⑱	T	71.7/16.9
	7030007340	S.RES ERJ2GEJ 153 X (15 k) except ④, ⑥, ⑬, ⑱	T	71.7/16.9
R309	7030005050	S.RES ERJ2GEJ 103 X (10 k)	B	7/14.1
R315	7210003061	VAR TP76N00N-15F-A103-2251A		
R318	7030005700	S.RES ERJ2GEJ 274 X (270 k)	T	95.9/3.9
R319	7030005090	S.RES ERJ2GEJ 104 X (100 k)	T	94.3/3.4
R320	7030005090	S.RES ERJ2GEJ 104 X (100 k)	B	93.7/9
R321	7030005090	S.RES ERJ2GEJ 104 X (100 k)	B	14.6/41.6
R323	7030005050	S.RES ERJ2GEJ 103 X (10 k)	B	5.3/26.6
R325	7030005050	S.RES ERJ2GEJ 103 X (10 k)	B	5.3/25.6
R327	7030005050	S.RES ERJ2GEJ 103 X (10 k)	B	5.3/24.6
R329	7030005050	S.RES ERJ2GEJ 103 X (10 k)	B	5.3/23.6
R331	7030005050	S.RES ERJ2GEJ 103 X (10 k)	B	5.3/22.6
R333	7030005050	S.RES ERJ2GEJ 103 X (10 k)	B	5.3/21.6
R335	7030005050	S.RES ERJ2GEJ 103 X (10 k)	B	5.3/20.6
R336	7030009710	S.RES ERJ2GEJ 203 X (20 k)	B	7/26.6
R337	7030009710	S.RES ERJ2GEJ 203 X (20 k)	B	7/25.6
R338	7030009710	S.RES ERJ2GEJ 203 X (20 k)	B	7/24.6
R339	7030009710	S.RES ERJ2GEJ 203 X (20 k)	B	7/23.6
R340	7030009710	S.RES ERJ2GEJ 203 X (20 k)	B	7/22.6
R341	7030009710	S.RES ERJ2GEJ 203 X (20 k)	B	7/21.6
R342	7030009710	S.RES ERJ2GEJ 203 X (20 k)	B	7/20.6
R343	7030009710	S.RES ERJ2GEJ 203 X (20 k)	B	7/19.6
R344	7030009710	S.RES ERJ2GEJ 203 X (20 k)	B	5.3/19.6
R345	7030005120	S.RES ERJ2GEJ 102 X (1 k)	T	81/38.6
R346	7030005120	S.RES ERJ2GEJ 102 X (1 k)	T	82/38.6
R347	7030005120	S.RES ERJ2GEJ 102 X (1 k)	T	83/38.6
R348	7030005120	S.RES ERJ2GEJ 102 X (1 k)	T	84.1/33.2
R349	7030005120	S.RES ERJ2GEJ 102 X (1 k)	B	28.0/10.4
R350	7030005120	S.RES ERJ2GEJ 102 X (1 k)	B	22.7/15.1
R351	7030005120	S.RES ERJ2GEJ 102 X (1 k)	B	31.4/20.8
R352	7030005120	S.RES ERJ2GEJ 102 X (1 k)	B	8.5/26.9
R353	7030005120	S.RES ERJ2GEJ 102 X (1 k)	B	13.9/13.6
R354	7030005120	S.RES ERJ2GEJ 102 X (1 k)	B	12.7/14
R355	7030005120	S.RES ERJ2GEJ 102 X (1 k)	B	11.4/14.3
R356	7030005120	S.RES ERJ2GEJ 102 X (1 k)	B	11.5/15.4
R357	7030006610	S.RES ERJ2GEJ 394 X (390 k)	B	34.4/41.1
R358	7030006610	S.RES ERJ2GEJ 394 X (390 k)	B	34.4/36.3
R359	7030010040	S.RES ERJ2GEJ-JPW	T	84/30.6
R360	7030005050	S.RES ERJ2GEJ 103 X (10 k)	T	95.5/39.6
R361	7030005120	S.RES ERJ2GEJ 102 X (1 k) ③, ⑤, ⑥, ⑬, ⑱, ⑲	B	89/31.1
	7			

[MAIN UNIT]

S.=Surface mount

REF NO.	ORDER NO.	DESCRIPTION	M.	H/V LOCATION
C17	4550007120	S.TAN F92 1D 224MPA	T	78/26.3
C18	4030017510	S.CER ECJ0EC1H680J	B	98.2/34.9
C19	4030017350	S.CER ECJ0EC1H020B except ④, ⑥, ⑧, ⑭, ⑯, ⑰	B	88.6/41.2
	4030017520	S.CER ECJ0EC1H0R3B ④, ⑥, ⑧, ⑭, ⑯, ⑰	B	88.6/41.2
C21	4030017590	S.CER ECJ0EC1H070C	B	99.8/37.7
C22	4030017350	S.CER ECJ0EC1H020B	B	95.6/35.8
C24	4030017460	S.CER ECJ0EB1E102K	T	95/38.6
C25	4030017380	S.CER ECJ0EC1H050B	B	96.6/34.6
C26	4030017460	S.CER ECJ0EB1E102K	B	97.6/34.6
C27	4030017660	S.CER ECJ0EC1H330J	B	96.4/37.1
C28	4030017590	S.CER ECJ0EC1H070C	B	92/36
C29	4030017620	S.CER ECJ0EC1H100C	B	92/37
C30	4030017460	S.CER ECJ0EB1E102K	B	89.8/35
C31	4030017910	S.CER ECJ0EB1H152K	B	41.6/18.7
C32	4030017460	S.CER ECJ0EB1E102K	B	91.6/41.2
C33	4030017420	S.CER ECJ0EC1H470J	B	90.6/41.2
C34	4030017460	S.CER ECJ0EB1E102K	B	47.9/19.8
C35	4030017760	S.CER ECJ0EB1H222K	B	44.5/20.5
C36	4030017460	S.CER ECJ0EB1E102K	T	87.8/36.2
C37	4030017460	S.CER ECJ0EB1E102K	T	86.5/37.6
C39	4030017620	S.CER ECJ0EC1H100C	B	88.7/39.9
C40	4030017520	S.CER ECJ0EC1H0R3B	B	88.6/36.4
C41	4030017640	S.CER ECJ0EC1H150J	B	87/31.9
C42	4030017460	S.CER ECJ0EB1E102K	T	89.1/40.2
C43	4030017460	S.CER ECJ0EB1E102K	T	86.5/36.6
C44	4030017560	S.CER ECJ0EC1H2R5B	B	85.7/32.2
C45	4030017630	S.CER ECJ0EC1H120J	B	87.2/35.6
C46	4030017420	S.CER ECJ0EC1H470J	B	39.5/18
C47	4030016970	S.CER ECJ0EB1C223K	B	12.4/30.6
C48	4030017400	S.CER ECJ0EC1H220J	B	87.2/27.5
C49	4030017380	S.CER ECJ0EC1H050B	B	86.2/27.5
C49	4030017630	S.CER ECJ0EC1H120J	B	86.2/27.5
C50	4030017460	S.CER ECJ0EB1E102K	B	88.2/27.5
C51	4030017460	S.CER ECJ0EB1E102K	T	90.5/31.9
C52	4030017420	S.CER ECJ0EC1H470J	B	89/30.1
C53	4030016790	S.CER ECJ0EB1C103K	B	90.7/29.8
C54	4030017460	S.CER ECJ0EB1E102K	B	90.7/31.1
C56	4030017390	S.CER ECJ0EC1H180J	T	94.6/25.6
C57	4030017460	S.CER ECJ0EB1E102K	T	88.2/32
C58	4030017460	S.CER ECJ0EB1E102K	B	89.2/22.9
C59	4030017460	S.CER ECJ0EB1E102K	B	86.2/21.2
C60	4030017460	S.CER ECJ0EB1E102K	B	88.2/22.9
C61	4030017430	S.CER ECJ0EC1H101J	B	87.2/18.9
C62	4030017680	S.CER ECJ0EC1H820J	T	79.7/12.6
C63	4030017460	S.CER ECJ0EB1E102K	B	33.1/20.7
C64	4030017460	S.CER ECJ0EB1E102K	B	34.3/13.8
C65	4030017330	S.CER ECJ0EF1C104Z	B	17.6/32.9
C66	4030017460	S.CER ECJ0EB1E102K	T	77.8/15.1
C67	4030017460	S.CER ECJ0EB1E102K	B	78.1/12.6
C69	4030017750	S.CER ECJ0EB1E122K	T	77.9/19.2
C70	4030017460	S.CER ECJ0EB1E102K ①, ②, ⑧, ⑨, ⑩, ⑪, ⑫, ⑬, ⑱, ⑳	T	77.9/20.2
	4030017740	S.CER ECJ0EB1E821K ③, ④, ⑤, ⑥, ⑦, ⑬, ⑭, ⑮, ⑯, ⑰	T	77.9/20.2
C71	4030017330	S.CER ECJ0EF1C104Z	T	79.9/21.3
C72	4030017420	S.CER ECJ0EC1H470J	T	84.5/12.3
C73	4030017460	S.CER ECJ0EB1E102K	T	91.8/13.2
C74	4030017460	S.CER ECJ0EB1E102K	B	86.6/6
C75	4550007600	S.TAN F920J106MPABMA	B	75.6/12.2
C76	4030016790	S.CER ECJ0EB1C103K	T	90.3/13.7
C77	4030017460	S.CER ECJ0EB1E102K	B	88/16.4
C78	4030017460	S.CER ECJ0EB1E102K	T	85.2/7.4
C79	4030006860	S.CER C1608 JB 1H 102K-T	T	87.9/9
C79	4030011600	S.CER C1608 JB 1E 104K-T	T	87.9/9
C80	4030016790	S.CER ECJ0EB1C103K	T	85.5/14.4
C90	4030017400	S.CER ECJ0EC1H220J	B	44.7/6.3
C95	4030017710	S.CER ECJ0EC1H181J	B	38.9/8.3
C98	4030017400	S.CER ECJ0EC1H220J	B	32/5.5
C100	4030017590	S.CER ECJ0EC1H070C	B	84.6/20.6
C102	4030017380	S.CER ECJ0EC1H050B	B	77.8/29.5
C103	4030017560	S.CER ECJ0EC1H2R5B	B	77.9/30.8
C104	4030017460	S.CER ECJ0EB1E102K	B	75.8/28
C105	4030017460	S.CER ECJ0EB1E102K	B	79.6/29.5
C106	4030017420	S.CER ECJ0EC1H470J	B	79.2/22.2
C107	4030017460	S.CER ECJ0EB1E102K	B	80.2/25.8
C108	4030016790	S.CER ECJ0EB1C103K	B	86.6/16.4
C109	4030017460	S.CER ECJ0EB1E102K	B	80.2/26.7
C110	4030017730	S.CER ECJ0EB1E471K	B	76.8/27.9
C111	4030017420	S.CER ECJ0EC1H470J	T	69.2/32.8
C112	4030017750	S.CER ECJ0EB1E122K	B	35.5/7.7
C113	4030017540	S.CER ECJ0EC1HR75B	B	71.7/30.4
C114	4030017380	S.CER ECJ0EC1H050B	B	72.4/32.9
C115	4030017630	S.CER ECJ0EC1H120J	B	74.5/34.3
C116	4030016790	S.CER ECJ0EB1C103K	B	76.6/34.3
C117	4030017730	S.CER ECJ0EB1E471K	B	76.6/32.7
C118	4030017540	S.CER ECJ0EC1HR75B	B	73.5/27.9
C119	4030017460	S.CER ECJ0EB1E102K	B	75.9/22.7
C120	4030017730	S.CER ECJ0EB1E471K	B	75.9/23.7
C121	4030017620	S.CER ECJ0EC1H100C	B	43.8/25.3
C121	4030017640	S.CER ECJ0EC1H150J	B	73.8/25.3
C122	4030017390	S.CER ECJ0EC1H180J	B	73.4/26.6
C123	4030017640	S.CER ECJ0EC1H150J	B	73/22.9
C124	4030017340	S.CER ECJ0EC1H010B ④, ⑤, ⑥, ⑦, ⑭, ⑮, ⑯, ⑰ only	B	40.6/8.3
C125	4030018110	S.CER ECJ0EB1H272K	B	70.9/31.8
C126	4030017640	S.CER ECJ0EC1H150J	B	34.2/7.2
C128	4030017330	S.CER ECJ0EF1C104Z	B	69.5/23.4
C129	4030017530	S.CER ECJ0EC1H0R5B	B	36.1/9.4
C130	4030017330	S.CER ECJ0EF1C104Z	B	43/19.4
C131	4030017330	S.CER ECJ0EF1C104Z	B	43/19.4
C132	4030017460	S.CER ECJ0EB1E102K	T	71.8/19.7

①: GT [MTG-01] ②: GT [MTE-01] ③: GT [USA-01] ④: GT [USA-02] ⑤: GT [GEN-01]
⑥: GT [GEN-02] ⑦: GT [EUR-01] ⑧: GT [AUS-02] ⑨: GT [CHN-01] ⑩: GT [USA-04]

[MAIN UNIT]

M.=T: Mounted on the Top side, B: Mounted on the Bottom side

REF NO.	ORDER NO.	DESCRIPTION	M.	H/V LOCATION
C133	4030017640	S.CER ECJ0EC1H150J	B	70.3/24.3
C134	4030017630	S.CER ECJ0EC1H120J ③, ⑤, ⑦, ⑬, ⑮, ⑰	B	69.9/31.8
	4030017640	S.CER ECJ0EC1H150J ①, ②, ⑨, ⑩, ⑪, ⑫, ⑱, ⑳	B	69.9/31.8
	4030018120	S.CER ECJ0EC1H110J ④, ⑥, ⑧, ⑭, ⑯, ⑲	B	69.9/31.8
C135	4030017460	S.CER ECJ0EB1E102K	T	76.4/26.2
C136	4030017430	S.CER ECJ0EC1H101J	B	36.4/43.6
C137	4030016790	S.CER ECJ0EB1C103K	B	86.5/23.4
C138	4030017420	S.CER ECJ0EC1H470J	T	72.1/27.3
C139	4030017330	S.CER ECJ0EF1C104Z	B	79.8/27.9
C140	4030017460	S.CER ECJ0EB1E102K	T	84.5/37.1
C141	4030017460	S.CER ECJ0EB1E102K	T	73.6/21.3
C142	4030017330	S.CER ECJ0EF1C104Z	B	68.7/41.9
C143	4030017460	S.CER ECJ0EB1E102K	T	77.2/23.6
C144	4030016950	S.CER ECJ0EB1A473K	T	69.8/20.3
C145	4030017420	S.CER ECJ0EC1H470J	T	76.4/27.6
C146	4030016950	S.CER ECJ0EB1A473K	B	68.7/40.9
C147	4030017420	S.CER ECJ0EC1H470J	T	86.5/32.4
C148	4550006250	S.TAN TEESVA 1A 106M8R	T	86.5/32.4
C149	4030017730	S.CER ECJ0EB1E471K	B	67.2/7.6
C150	4030017490	S.CER C1608 JB 1A 105K-T	T	70.8/18.3
C151	4030017460	S.CER ECJ0EB1E102K	B	24.4/15.1
C152	4030017420	S.CER ECJ0EC1H470J	T	83.2/40.2
C153	4030017420	S.CER ECJ0EC1H470J	T	82.2/40.2
C154	4030017420	S.CER ECJ0EC1H470J	T	81.2/40.2
C155	4030017460	S.CER ECJ0EB1E102K	T	73.1/32.6
C156	4030017430	S.CER ECJ0EC1H101J	B	64.9/35.4
C157	4030017620	S.CER ECJ0EC1H100C	B	63.1/35.4
C158	4030017330	S.CER ECJ0EF1C104Z	B	61.7/35.3
C159	4030017460	S.CER ECJ0EB1E102K	B	59.4/38.7
C160	4030017460	S.CER ECJ0EB1E102K except ④, ⑥, ⑧, ⑭, ⑯, ⑰	T	69.5/12
	4030017730	S.CER ECJ0EB1E471K ④, ⑥, ⑧, ⑭, ⑯, ⑰	T	69.5/12
C161	4030017620	S.CER ECJ0EC1H100C	T	83.3/27.6
C162	4030017500	S.CER ECJ0EC1H560J	T	83.2/24
C163	4030017570	S.CER ECJ0EC1H040B	T	84.5/23.4
C164	4030017590	S.CER ECJ0EC1H070C	T	83.2/23
C165	4030016790	S.CER ECJ0EB1C103K	T	83.2/25.3
C166	4030017360	S.CER ECJ0EC1H030B	T	83.1/21.7
C167	4030017330	S.CER ECJ0EF1C104Z	B	83.1/11.6
C168	4030017460	S.CER ECJ0EB1E102K except ④, ⑥, ⑧, ⑭, ⑯, ⑰	T	75/8.5
	4030017730	S.CER ECJ0EB1E471K ④, ⑥, ⑧, ⑭, ⑯, ⑰	T	75/8.5
C169	4030017420	S.CER ECJ0EC1H470J	B	68.8/7
C170	4030017330	S.CER ECJ0EF1C104Z	B	51.1/26
C171	4030017460	S.CER ECJ0EB1E102K	B	70.3/40.9
C172	4030016950	S.CER ECJ0EB1A473K	B	52.1/26
C174	4030017710	S.CER ECJ0EC1H181J	B	53.5/28.1
C175	4030017420	S.CER ECJ0EC1H470J	B	71.8/41.4
C176	4030017330	S.CER ECJ0EF1C104Z	T	99.4/36.2
C177	4030017330	S.CER ECJ0EF1C104Z	B	100.3/41.5
C180	4030017330	S.CER ECJ0EF1C104Z	B	55.2/31.9
C182	4030017460	S.CER ECJ0EB1E102K	B	87.2/22.9
C183	4030017640	S.CER ECJ0EC1H150J	B	84.9/32.8
C184	4030017460	S.CER ECJ0EB1E102K	T	90.6/38.9
C185	4030017460	S.CER ECJ0EB1E102K	T	89.6/38.9
C186	4030017330	S.CER ECJ0EF1C104Z	T	89.1/36.8
C188	4030017460	S.CER ECJ0EB1E102K	T	82.8/12.2
C191	4030017380	S.CER ECJ0EC1H050B ④, ⑥, ⑧, ⑭, ⑯, ⑰	B	70.4/30.4
	4030018120	S.CER ECJ0EC1H110J except ④, ⑥, ⑧, ⑭, ⑯, ⑰	B	70.4/30.4
C192	4030017370	S.CER ECJ0EC1H3R5B ⑧, ⑯	B	70/25.7
	4030017570	S.CER ECJ0EC1H040B ④, ⑥, ⑭, ⑰	B	70/25.7
	4030017580	S.CER ECJ0EC1H060C ①, ②, ⑨, ⑩, ⑪, ⑫, ⑱, ⑳	B	70/25.7
	4030017610	S.CER ECJ0EC1H090C ③, ⑤, ⑦, ⑬, ⑮, ⑰	B	70/25.7
C193	4030017420	S.CER ECJ0EC1H470J ①, ②, ⑦, ⑨, ⑩, ⑪, ⑫, ⑱, ⑲, ⑳ only	B	66.9/31.5
C205	4030017380	S.CER ECJ0EC1H050B	T	79.9/33.1
C206	4030017590	S.CER ECJ0EC1H070C	B	78.1/33.9
C208	4030017590	S		

[MAIN UNIT]

S.=Surface mount

REF NO.	ORDER NO.	DESCRIPTION	M.	H/V LOCATION
C314	4030017740	S.CER ECJ0EB1E821K	B	55.2/18.7
C315	4030017330	S.CER ECJ0EF1C104Z	B	49.2/20.6
C316	4030017420	S.CER ECJ0EC1H470J	B	57.4/19.1
C317	4030017770	S.CER ECJ0EB1E332K	B	59.2/17.7
C318	4030017690	S.CER ECJ0EC1H121J	B	57.3/28.5
C319	4030017760	S.CER ECJ0EB1H222K	B	58.9/23.8
C320	4030017460	S.CER ECJ0EB1E102K	B	60.2/27
C321	4030017460	S.CER ECJ0EB1E102K	T	91.1/3.1
C322	4030017420	S.CER ECJ0EC1H470J	T	100.1/18.6
C323	4030016950	S.CER ECJ0EB1A473K	T	94.5/20.4
C324	4550007110	S.TAN SY6-1A107M-RC	B	99.4/16.5
C325	4550006250	S.TAN TEESVA 1A 106M8R	T	101.4/15.8
C326	4550007080	S.TAN TEESVA 1C 106M8R	T	92.9/16.9
C327	4030017330	S.CER ECJ0EF1C104Z	T	93.8/13.6
C328	4030017460	S.CER ECJ0EB1E102K	T	87.7/20.3
C329	4030017460	S.CER ECJ0EB1E102K	T	87.7/21.3
C330	4030017330	S.CER ECJ0EF1C104Z	T	92.9/21.1
C331	4030017460	S.CER ECJ0EB1E102K	T	101.7/12.4
C332	4030017460	S.CER ECJ0EB1E102K	T	82.9/3.7
C333	4550007040	S.TAN ECST0J106R ③, ④, ⑤, ⑥, ⑦, ⑬, ⑭, ⑮, ⑯, ⑰, ⑱ only	T	81.5/4
C334	4030017330	S.CER ECJ0EF1C104Z	T	75.7/5.4
C335	4030018860	S.CER ECJ0EB0J105K	B	40/32.9
C336	4030017730	S.CER ECJ0EB1E471K	B	40/36.9
C337	4030017490	S.CER C1608 JB 1A 105K-T	T	96.4/7.9
C338	4030017330	S.CER ECJ0EF1C104Z	B	34.5/20.7
C339	4030016790	S.CER ECJ0EB1C103K	B	32.6/18
C340	4030017330	S.CER ECJ0EF1C104Z	B	9.6/16.5
C345	4030017330	S.CER ECJ0EF1C104Z	B	19/34.9
C346	4030017600	S.CER ECJ0EC1H080C	B	27.5/26.4
C347	4030017640	S.CER ECJ0EC1H150J	B	27.4/36
C348	4030017400	S.CER ECJ0EC1H220J	B	26.6/28
C349	4030017330	S.CER ECJ0EF1C104Z	B	26/31.5
C350	4030017330	S.CER ECJ0EF1C104Z	B	27.3/33
C351	4030017330	S.CER ECJ0EF1C104Z	B	27.4/35
C352	4030017030	S.CER ECJ0EB1A273K	B	23/41.3
C353	4030017330	S.CER ECJ0EF1C104Z	B	14/32
C354	4030016790	S.CER ECJ0EB1C103K	B	30.8/18
C355	4030017460	S.CER ECJ0EB1E102K	B	51.5/7.6
C356	4030017330	S.CER ECJ0EF1C104Z	B	15.4/4
C357	4030018560	S.CER C2012 JB 1A 475K-T	B	25.4/40.9
C359	4030017330	S.CER ECJ0EF1C104Z	B	21.6/38.8
C360	4030017330	S.CER ECJ0EF1C104Z	B	49.8/26.5
C368	4030017460	S.CER ECJ0EB1E102K	T	95.5/41.6
C369	4030017400	S.CER ECJ0EC1H220J	B	94.2/39.5
	4030017660	S.CER ECJ0EC1H330J except ④, ⑥, ⑧, ⑩, ⑬, ⑮, ⑰	B	94.2/39.5
C371	4030017330	S.CER ECJ0EF1C104Z	B	45.9/32.5
C375	4030017460	S.CER ECJ0EB1E102K	T	86/18
C376	4030017460	S.CER ECJ0EB1E102K	T	86/17
C377	4030017460	S.CER ECJ0EB1E102K	B	30.4/8.7
C378	4030017460	S.CER ECJ0EB1E102K	B	37.9/44.2
C379	4030017460	S.CER ECJ0EB1E102K	T	84.1/3.7
C380	4030017330	S.CER ECJ0EF1C104Z	B	36.8/33.6
C384	4030018100	S.CER ECJ0EB1H681K	T	61.7/15.4
C386	4030017330	S.CER ECJ0EF1C104Z	T	58.6/13.3
C387	4030017330	S.CER ECJ0EF1C104Z	T	59.8/13.3
C388	4030017330	S.CER ECJ0EF1C104Z	T	60.9/14.1
C390	4030017420	S.CER ECJ0EC1H470J	T	79.5/28.8
C393	4030017330	S.CER ECJ0EF1C104Z	T	77.8/16.1
C394	4030017330	S.CER ECJ0EF1C104Z	T	78.2/17.4
C395	4030017420	S.CER ECJ0EC1H470J	B	91.4/34.8
C396	4030017360	S.CER ECJ0EC1H030B	B	84.7/24.8
C397	4030017580	S.CER ECJ0EC1H060C	B	84.9/27
C398	4030017460	S.CER ECJ0EB1E102K	B	68.1/34.3
C399	4550007120	S.TAN F92 1D 224MPA	T	67.5/35.4
C400	4030017460	S.CER ECJ0EB1E102K	B	72.2/27.5
C401	4030017330	S.CER ECJ0EF1C104Z	B	71.3/28.2
C402	4030017460	S.CER ECJ0EB1E102K	T	92.9/19.9
C403	4030017460	S.CER ECJ0EB1E102K	B	36.3/16.6
C404	4030016790	S.CER ECJ0EB1C103K	B	59.1/35.3
C405	4030017460	S.CER ECJ0EB1E102K	B	39.4/42.9
C406	4030017330	S.CER ECJ0EF1C104Z	B	52.3/19.5
C407	4030017460	S.CER ECJ0EB1E102K	T	95.9/2.9
C408	4030017460	S.CER ECJ0EB1E102K	T	100.9/4.2
C409	4030017460	S.CER ECJ0EB1E102K	B	16.6/32.9
C411	4030017330	S.CER ECJ0EF1C104Z	B	18.6/32.4
C412	4030017420	S.CER ECJ0EC1H470J	T	78.4/3.1
C413	4030018080	S.CER ECJ0EB1H182K	T	74.9/16.9
C414	4030018860	S.CER ECJ0EB0J105K	B	34.5/34.2
C415	4030017520	S.CER ECJ0EC1H0R3B	B	69.1/34.4
C416	4030018860	S.CER ECJ0EB0J105K	T	91.3/14.4
C417	4030017330	S.CER ECJ0EF1C104Z	T	80.9/12.2
C418	4030017420	S.CER ECJ0EC1H470J	B	80.6/22.6
C419	4030017620	S.CER ECJ0EC1H100C	B	79.3/23.1
C420	4030017380	S.CER ECJ0EC1H050B except ⑤, ⑥, ⑮, ⑰	T	94.6/28.5
	4030017620	S.CER ECJ0EC1H100C ⑤, ⑥, ⑮, ⑰	T	94.6/28.5
C421	4550006780	S.TAN TEESVB2 0J 476M8R	B	30.5/41.2
C422	4550006780	S.TAN TEESVB2 0J 476M8R	B	55.6/15.4
C423	4030017730	S.CER ECJ0EB1E471K	T	84.9/29.9
C424	4030017730	S.CER ECJ0EB1E471K	T	97.9/42.3
C425	4030017420	S.CER ECJ0EC1H470J	T	70.7/27.1
J2	6450002250	CNR HSJ1456-010320		
J3	6450001680	CNR HSJ1122-010010		
J4	6510021901	S.CNR BM02B-ASRS-TF	T	88.1/4.5
J5	6510018430	S.CNR AXN330C038P	B	15.2/9.8
J6	6510024391	S.CNR IMSA-6176S-03Y902	B	88.2/8.8
J7	6510024740	S.CNR IPS-4039T-02B (4039T-01Y901)	B	92.5/29

①: GT [MTG-01] ②: GT [MTE-01] ③: GT [USA-01] ④: GT [USA-02] ⑤: GT [GEN-01]
⑥: GT [GEN-02] ⑦: GT [EUR-01] ⑧: GT [AUS-02] ⑨: GT [CHN-01] ⑩: GT [USA-04]

[MAIN UNIT]

M.=T: Mounted on the Top side, B: Mounted on the Bottom side

REF NO.	ORDER NO.	DESCRIPTION	M.	H/V LOCATION
DS1	5010000160	S.LED LNJ310M6URA	T	57.3/6
DS2	5010000160	S.LED LNJ310M6URA	T	57.3/39.4
DS3	5030002760	LCD L3-0200HAY-3 (-4)		
MC1	7700002480	MIC SKB-2746 LPC		
S1	2230001060	S.SW EVQ-PUL 02K	T	102.2/38.1
S2	2260002840	SW SKHLLFA010		
S3	2260002800	S.SW SW-167 (SKQTLAE010)	B	61.1/44.2
S4	2260002800	S.SW SW-167 (SKQTLAE010)	B	51.6/44.2
S5	2260002800	S.SW SW-167 (SKQTLAE010)	B	99.6/44.2
S27	2250000180	ECR EC10SP16-47		
EP1	6910015370	S.BEA ACZ1005Y-102-T	B	76.6/30.8
EP3	6910015370	S.BEA ACZ1005Y-102-T	B	59.4/36.9
EP4	6910015370	S.BEA ACZ1005Y-102-T	B	37.4/19
EP5	6910015370	S.BEA ACZ1005Y-102-T	B	32/8.3
EP6	6910015370	S.BEA ACZ1005Y-102-T	T	74.4/31.6
EP7	8930063020	LCT SRCN-2721-SP-N-W		
EP11	6910015370	S.BEA ACZ1005Y-102-T	T	78/11.7
EP12	0800008200	ADP IC20-DES TRANSCRYPT		

[PA UNIT]

REF NO.	ORDER NO.	DESCRIPTION	M.	H/V LOCATION
Q701	1560001231	S.FET RD07MVS1-T112	B	22.6/8.3
Q702	1560001241	S.FET RD01MUS1-T113	B	15.7/8.2
Q703	1530000370	S.TR 2SC3356-T1B	T	8.4/14
Q704	1530003260	S.TR 2SC5006-T1	T	3.9/7
D701	1750000581	S.DIO 1SV307 (TPH3,F)	T	33.9/12.8
D702	1790001670	S.DIO RB706F-40T106	T	28.8/17.8
D703	1790001670	S.DIO RB706F-40T106	B	30.9/13.6
D704	1790001260	S.DIO MA2S077-(TX)	B	29.3/18
D705	1790001240	S.DIO MA2S728-(TX)	T	25.9/18.1
L701	6200002851	S.COL NLV25T-R82J	B	34.4/12.4
L703	6200009470	S.COL 0.40-0.9-2TL except ①, ②, ⑧, ⑩, ⑫, ⑰	T	30.1/13.6
	6200012610	S.COL 0.40-0.9-2TL 2.8N ①, ②, ⑧, ⑩, ⑫, ⑰	T	30.1/13.6
L704	6200009470	S.COL 0.40-0.9-2TL except ①, ②, ⑧, ⑩, ⑫, ⑰	T	24.1/14.1
	6200012610	S.COL 0.40-0.9-2TL 2.8N ①, ②, ⑧, ⑩, ⑫, ⑰	T	24.1/14.1
L705	6200008240	S.COL 0.30-0.9-5TL 14N except ①, ②, ⑧, ⑩, ⑫, ⑰	B	19.4/13.5
	6200013010	S.COL 0.30-0.9-5TL 10.3N ①, ②, ⑧, ⑩, ⑫, ⑰	B	19.4/13.5
L706	6200003590	S.COL EXCCL3225U1	B	10.7/15.9
L707	6200005680	S.COL ELJRE 15NG-F ④, ⑥, ⑭, ⑮, ⑱	T	9.1/16.1
	6200005681	S.COL ELJRE 15NGFA ⑧	T	9.1/16.1
	6200005690	S.COL ELJRE 18NG-F ③, ⑤, ⑦, ⑩, ⑬, ⑮, ⑰, ⑱	T	9.1/16.1
	6200005691	S.COL ELJRE 18NGFA ①, ②, ⑨, ⑪, ⑫, ⑰	T	9.1/16.1
L708	6200005741	S.COL ELJRE 47NGFA	T	3.3/10.3
L709	6200008240	S.COL 0.30-0.9-5TL 14N except ①, ②, ⑧, ⑩, ⑫, ⑰	T	33.7/16.7
	6200013010	S.COL 0.30-0.9-5TL 10.3N ①, ②, ⑧, ⑩, ⑫, ⑰	T	33.7/16.7
L712	6200009070	S.COL LQW18AN18NG00D	B	32.2/15.8
R701	7030004980	S.RES ERJ2GEJ 101 X (100)	B	31.4/11.8
R702	7030005030	S.RES ERJ2GEJ 152 X (1.5 k)	T	29.6/15.7
R702	7030005120	S.RES ERJ2GEJ 102 X (1 k)	T	29.6/15.7
R703	7030005120	S.RES ERJ2GEJ 102 X (1 k)	B	27.2/16.3
R704	7030005530	S.RES ERJ2GEJ 100 X (10)	T	18.4/2.9
R705	7030005220	S.RES ERJ2GEJ 223 X (22 k) ④, ⑥, ⑧, ⑭, ⑮, ⑱ only	T	16.9/2.4
R706	7030005040	S.RES ERJ2GEJ 472 X (4.7 k)	T	14.5/2.9
R708	7030004990	S.RES ERJ2GEJ 221 X (220)	B	12.8/11.4
R710	7030005040	S.RES ERJ2GEJ 472 X (4.7 k)	B	10.8/10.7
R712	7030005220	S.RES ERJ2GEJ 223 X (22 k)	T	4.5/13.9
R715	7030005220	S.RES ERJ2GEJ 223 X (22 k)	T	3.8/8.9
R726	7030005120	S.RES ERJ2GEJ 102 X (1 k)	B	27.7/14.9
R727	7030005030	S.RES ERJ2GEJ 152 X (1.5 k) ③, ④, ⑥, ⑧, ⑬, ⑮, ⑱	B	34.9/14.7
	7030005120	S.RES ERJ2GEJ 102 X (1 k) except ③, ④, ⑥, ⑧, ⑬, ⑮, ⑱	B	34.9/14.7
R728	7030010040	S.RES ERJ2GEJ-JPW except ④, ⑥, ⑧, ⑭, ⑮, ⑱	B	19/11.1
	7030011210	S.RES ERJ2GEJ 1ROV (1) ④, ⑥, ⑧, ⑭, ⑮, ⑱	B	19/11.1
R729	7030004990	S.RES ERJ2GEJ 221 X (220)		
C701	4030017460	S.CER ECJ0EB1E102K	T	35/10.7
C702	4030017420	S.CER ECJ0EC1H470J	B	31.3/10.5
C703	4030017460	S.CER ECJ0EB1E102K	B	32.3/10.5
C705	4030006990	S.CER C1608 CH 1H 080D-T except ④, ⑥, ⑧, ⑭, ⑮, ⑱	T	31.4/10.9
	4030009520	S.CER C1608 CH 1H 020B-T ④, ⑥, ⑧, ⑭, ⑮, ⑱	T	31.4/10.9

①: GS [MTG-01] ②: GS [MTE-01] ③: GS [USA-01] ④: GS [USA-02] ⑤: GS [GEN-01]
⑥: GS [GEN-02] ⑦: GS [EUR-01] ⑧: GS [AUS-02] ⑨: GS [USA-04] ⑩: GS [CHN-01]

[PA UNIT]

REF NO.	ORDER NO.	DESCRIPTION	M.	H/V LOCATION
C707	4030017460	S.CER ECJ0EB1E102K	B	26.3/17.6
C708	4030006860	S.CER C1608 JB 1H 102K-T	T	28.5/13.7
C709	4030006980	S.CER C1608 CH 1H 070D-T	T	27.3/13.7
	4030011770	S.CER C1608 CH 1H 060B-T	T	27.3/13.7
C711	4030006960	S.CER C1608 CH 1H 050C-T	T	25.9/13.7
C712	4030007020	S.CER C1608 CH 1H 120J-T	T	22.3/13.8
	4030007040	S.CER C1608 CH 1H 180J-T	T	22.3/13.8
C713	4030008560	S.CER C1608 CH 1H 300J-T	B	27/13.2
C715	4030017460	S.CER ECJ0EB1E102K	B	15.4/13.1
C716	4030017460	S.CER ECJ0EB1E102K	B	14.4/13.1
C718	4030017460	S.CER ECJ0EB1E102K	T	15.9/2.4
C719	4030016790	S.CER ECJ0EB1C103K	B	12.7/13.1
C720	4030017670	S.CER ECJ0EC1H390J	B	19/8.4
	4030018070	S.CER ECJ0EC1H300J	B	19/8.4
C721	4030017380	S.CER ECJ0EC1H050B	B	17.2/11.5
C722	4030017420	S.CER ECJ0EC1H470J	B	16.4/13.1
C723	4030017460	S.CER ECJ0EB1E102K	B	10.6/9.8
C724	4030017460	S.CER ECJ0EB1E102K	B	8.3/16
C725	4030017420	S.CER ECJ0EC1H470J	T	10.6/13.3
C726	4030017460	S.CER ECJ0EB1E102K	T	11.6/13.3
C727	4030017460	S.CER ECJ0EB1E102K	T	12.6/13.3
C729	4030017360	S.CER ECJ0EC1H030B	B	11/11.8
	4030017370	S.CER ECJ0EC1H3R5B	B	11/11.8
	4030017580	S.CER ECJ0EC1H060C	B	11/11.8
C731	4030017360	S.CER ECJ0EC1H030B	T	4.1/12.9
C732	4030017460	S.CER ECJ0EB1E102K	T	5.1/10.6
C733	4030017360	S.CER ECJ0EC1H030B	T	4.9/5.5
C734	4030017730	S.CER ECJ0EB1E471K	T	13.1/2.4
C735	4030017360	S.CER ECJ0EC1H030B	T	3.5/11.5
C742	4030017460	S.CER ECJ0EB1E102K	T	34/14.5
C744	4030009910	S.CER C1608 CH 1H 040B-T	T	31.9/16.9
C745	4030009350	S.CER C1608 CH 1H 3R5B-T	T	35.5/15.4
C750	4030006980	S.CER C1608 CH 1H 070D-T	B	32.2/17
	4030006990	S.CER C1608 CH 1H 080D-T	B	32.2/17
	4030009920	S.CER C1608 CH 1H 050B-T	B	32.2/17
C751	4030017380	S.CER ECJ0EC1H050B	B	30.3/17.6
C752	4030017460	S.CER ECJ0EB1E102K	B	27.8/17.7
	4030017620	S.CER ECJ0EC1H100C	B	27.8/17.7
C753	4030017460	S.CER ECJ0EB1E102K	B	28.2/16.4
C754	4030017460	S.CER ECJ0EB1E102K	B	28.8/13.5
C755	4030007030	S.CER C1608 CH 1H 150J-T	T	20.7/13.8
	4030009910	S.CER C1608 CH 1H 040B-T	T	20.7/13.8
C756	4030017460	S.CER ECJ0EB1E102K	B	17.5/13.1
C757	4030017460	S.CER ECJ0EB1E102K	B	17.5/14.9
C758	4030017330	S.CER ECJ0EF1C104Z	T	12.1/2.4
C759	4030017330	S.CER ECJ0EF1C104Z	T	6/7.9
C760	4030017460	S.CER ECJ0EB1E102K	T	6.7/8.9
C761	4030017530	S.CER ECJ0EC1H0R5B	T	3/5.5
C762	4030017530	S.CER ECJ0EC1H0R5B	T	5.9/14.7
C763	4030017420	S.CER ECJ0EC1H470J	T	10.7/17.3
C766	4030017460	S.CER ECJ0EB1E102K	T	9.9/20.3
C767	4030017420	S.CER ECJ0EC1H470J	T	9.9/19.4
J701	6510024391	S.CNR IMSA-6176S-03Y902	B	6.3/9.7
J702	6910015891	CNR 9230B-1-02Z140-PT1		
F701	5210000901	S.FUS 0467003.NR (0434003)	B	10.9/19.6
EP711	6910015370	S.BEA ACZ1005Y-102-T	T	11.2/14.6
EP712	6910015370	S.BEA ACZ1005Y-102-T	T	6.1/10.2

[ANT UNIT]

REF NO.	ORDER NO.	DESCRIPTION	M.	H/V LOCATION
L801	6200010920	S.COL 0.30-1.2-4TR 15.0N	T	5.7/12.2
L802	6200010930	S.COL 0.30-1.2-5TR 21.0N	T	6.8/9.5
	6200012540	S.COL 0.30-1.2-5TR 16.1N	T	6.8/9.5
R801	7030003670	S.RES ERJ3GEYJ 823 V (82 k)	T	3.3/14
C802	4030009510	S.CER C1608 CH 1H 010B-T	T	6.5/7.7
C803	4030006980	S.CER C1608 CH 1H 070D-T	T	3.3/11.1
	4030007000	S.CER C1608 CH 1H 090D-T	T	3.3/11.1
C804	4030009530	S.CER C1608 CH 1H 030B-T	T	5/6.4
	4030009910	S.CER C1608 CH 1H 040B-T	T	5/6.4
C805	4030009350	S.CER C1608 CH 1H 3R5B-T	T	7.9/6.3
	4030009530	S.CER C1608 CH 1H 030B-T	T	7.9/6.3
C806	4030009510	S.CER C1608 CH 1H 010B-T	T	3.3/12.6

M.=Mounted side (T: Mounted on the Top side, B: Mounted on the Bottom side)
S.=Surface mount

[FUSE UNIT]

REF NO.	ORDER NO.	DESCRIPTION	M.	H/V LOCATION
L901	6200006190	S.COL BLM21PG300SN1D	T	8.1/5.8
L902	6200008210	S.COL 0.45-1.5-5TL 23.2N	T	3/5.2
L903	6200008210	S.COL 0.45-1.5-5TL 23.2N	T	11.7/6.7
C901	4030017460	S.CER ECJ0EB1E102K	T	5.9/4.3
C902	4030017420	S.CER ECJ0EC1H470J	T	8.4/8.6
C903	4030017460	S.CER ECJ0EB1E102K	T	9.3/8.6
C904	4030017420	S.CER ECJ0EC1H470J	T	12.5/9
C905	4030017460	S.CER ECJ0EB1E102K	T	13.4/9
C906	4030017420	S.CER ECJ0EC1H470J	T	5.9/5.2
J901	6910015881	CNR 9230B-1-02Z141-PT1		

①: GT [MTG-01] ②: GT [MTE-01] ③: GT [USA-01] ④: GT [USA-02] ⑤: GT [GEN-01]
⑥: GT [GEN-02] ⑦: GT [EUR-01] ⑧: GT [AUS-02] ⑨: GT [CHN-01] ⑩: GT [USA-04]
⑪: GS [MTG-01] ⑫: GS [MTE-01] ⑬: GS [USA-01] ⑭: GS [USA-02] ⑮: GS [GEN-01]
⑯: GS [GEN-02] ⑰: GS [EUR-01] ⑱: GS [AUS-02] ⑲: GS [USA-04] ⑳: GS [CHN-01]

SECTION 8

MECHANICAL PARTS

[CHASSIS PARTS]

REF NO.	ORDER NO.	DESCRIPTION	QTY.
J1	6910015910	ANT CONNECTOR 104	1
J2	6910015860	IMSA-6277S-Q2A-G	1
SP1	2510001061	K036NA500-67	1
W1	8900009640	OPC-963	1
MP1	8010019454	2721 CHASSIS-4	1
MP2	8210020531	2721 T-FRONT PANEL-1 (Inc. MP3, MP4, MP5, MP6, MP7)	[10-key] 1
	8210020731	2721 S-FRONT PANEL-1 (Inc. MP3, MP4, MP5, MP6, MP7)	[4-key] 1
MP3	8210020540	2721 PTT PANEL	1
MP4	8930061780	2721 PTT BUTTON	1
MP5	8930061800	2721 PTT RUBBER	1
MP6	8930040390	Speaker net (B)	1
MP7	8930046050	Speaker net (C)	1
MP8	8210020550	2721 REAR PANEL	1
MP9	8310060760	2721 WINDOW PLATE	1
MP10	8930065750	2721 A-WINDOW SHEET	1
MP12	8930061790	2721 KEYBOARD	[10-key] 1
	8930062760	2721 4-KEY	[4-key] 1
MP13	8930061710	2721 MAIN SEAL	1
MP14	8930063060	2721 T-RUBBER	1
MP16	8930064661	2721 SIDE PLATE (A)-1	1
MP17	8930061860	2721 TOP PLATE	1
MP20	8930061880	2721 MIC SPONGE	1
MP21	8930059360	2600 RELEASE BUTTON	1
MP22	8930063030	2721 RELEASE PLATE	1
MP23	8610007510	knob spring NO.7800	1
MP24	8610007920	knob spring NO.1500	1
MP25	8830001720	2721 ANT NUT	1
MP26	8810009221	Screw BT B0 2X8 NI-ZK3 (BT)	2
MP27	8810009561	Screw BT B0 2X6 NI-ZK3 (BT)	2
MP28	8810008971	Otap 1flat washerB0 2X3.5NI-ZC3 (BT)	11
MP29	8610011930	KNOB N-318	1
MP30	8610012130	KNOB N-323	1
MP31	8810010430	screw truss M3X5 SUS SSBC	1
MP32	8930063052	2721 PLATE-2	1
MP33	8930046020	1123 SHEET (A)-1	1
MP34	8930056540	Push spring (AH)	2
MP35	8830001701	VR NUT (Q)-1	1
MP36	8830001690	VR NUT (R)	1
MP37	8510016360	2721 MAIN SHIELD	1
MP38	8510016350	2721 ANT PLATE	1
MP42	8930062960	WHITE SHEET (R)	1
MP47	8930048870	2056 A-SPONGE	[F44GT/GS] only 1
MP48	8510016510	2721 PA-SHIELD PLATE	1
MP50	8510016761	2721 LO-SHIELD PLATE-1	[USA-02], [GEN-02], [AUS-02] only 1

[MAIN UNIT]

REF NO.	ORDER NO.	DESCRIPTION	QTY.
J2	6450002250	HSJ1456-010320	1
J3	6450001680	HSJ1122-010010	1
J4*	6510021901	BM02B-ASRS-TF (LF) (SN)	1
J5*	6510018430	AXN330C038	1
J6*	6510024391	IMSA-6176S-03Y902	1
J7*	6510024740	IPS-4039T-02B	1
DS3	5030003050	S11188	1
MC1	7700002760	EM6027P-46C33-G-01	1
S1*	2230001060	EVQ-PUL 02K	1
S2	2260002840	SKHLLFA010	1
S3*	2260002800	SW-167 (SKQT)	1
S4*	2260002800	SW-167 (SKQT)	1
S5*	2260002800	SW-167 (SKQT)	1
S27	2250000180	EC10SP16-47	1
EP7	8930063020	SRCN-2721-SP-N-W	2
MP1*	8510016130	2721 VCO CASE	1
MP2	8510016120	2721 VCO COVER	1
MP3	8930061890	2721 LCD HOLDER	1
MP4	8210020570	2721 REFLECTOR	1

*: Refer to SECTION 10 "BOARD LAYOUTS."

[PA UNIT]

REF NO.	ORDER NO.	DESCRIPTION	QTY.
J701*	6510024391	IMSA-6176S-03Y902	1
J702	6910015891	9230B-1-02Z140-PT1	1
F701*	5210000901	0467003.NR	1
MP701*	8410002370	2337 PA HEATSINK	1

[FUSE UNIT]

REF NO.	ORDER NO.	DESCRIPTION	QTY.
J901	6910015881	9230B-1-02Z141-PT1	1

[ACCESSORIES]

REF NO.	ORDER NO.	DESCRIPTION	QTY.
EP1 ①	Option	FA-SC57U-1	[others] 1
	Option	FA-SC72U-1	[GEN-02], [AUS-02] 1
EP2 ②	Option	BP-232N	1
MP1 ③	Option	MB-94	1
MP3 ⑤	8210020560	2721 JACK PANEL	1
MP4 ⑤	8810004861	Screw PH M2X6 ZK3	2
MP5 ④	8930063052	2721 PLATE-2	1

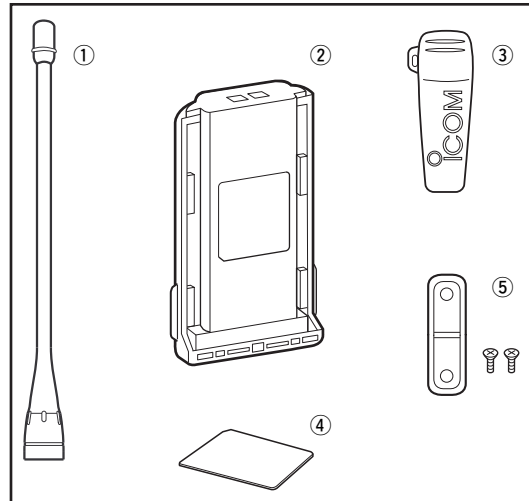

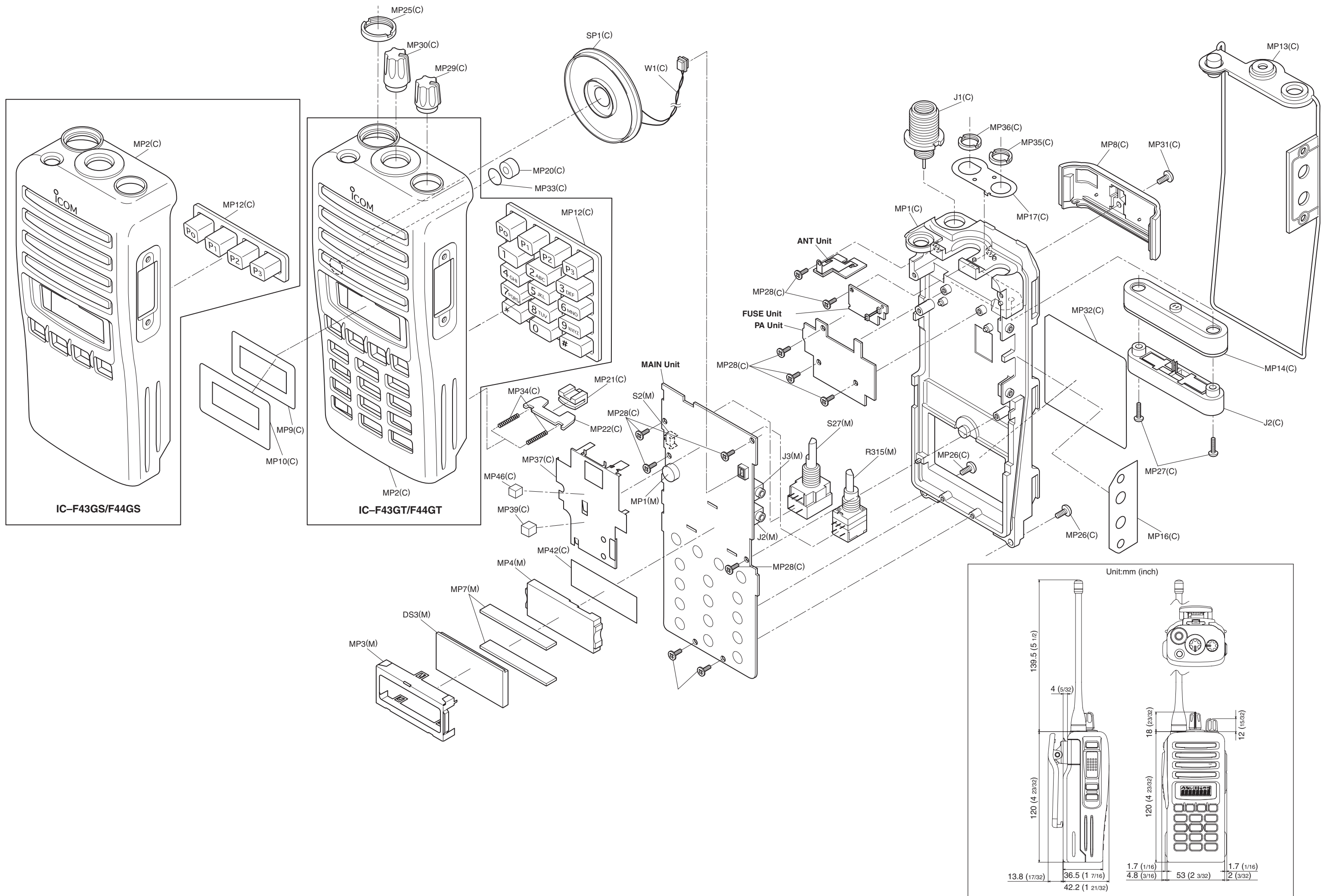

• MAIN UNIT (TOP VIEW)

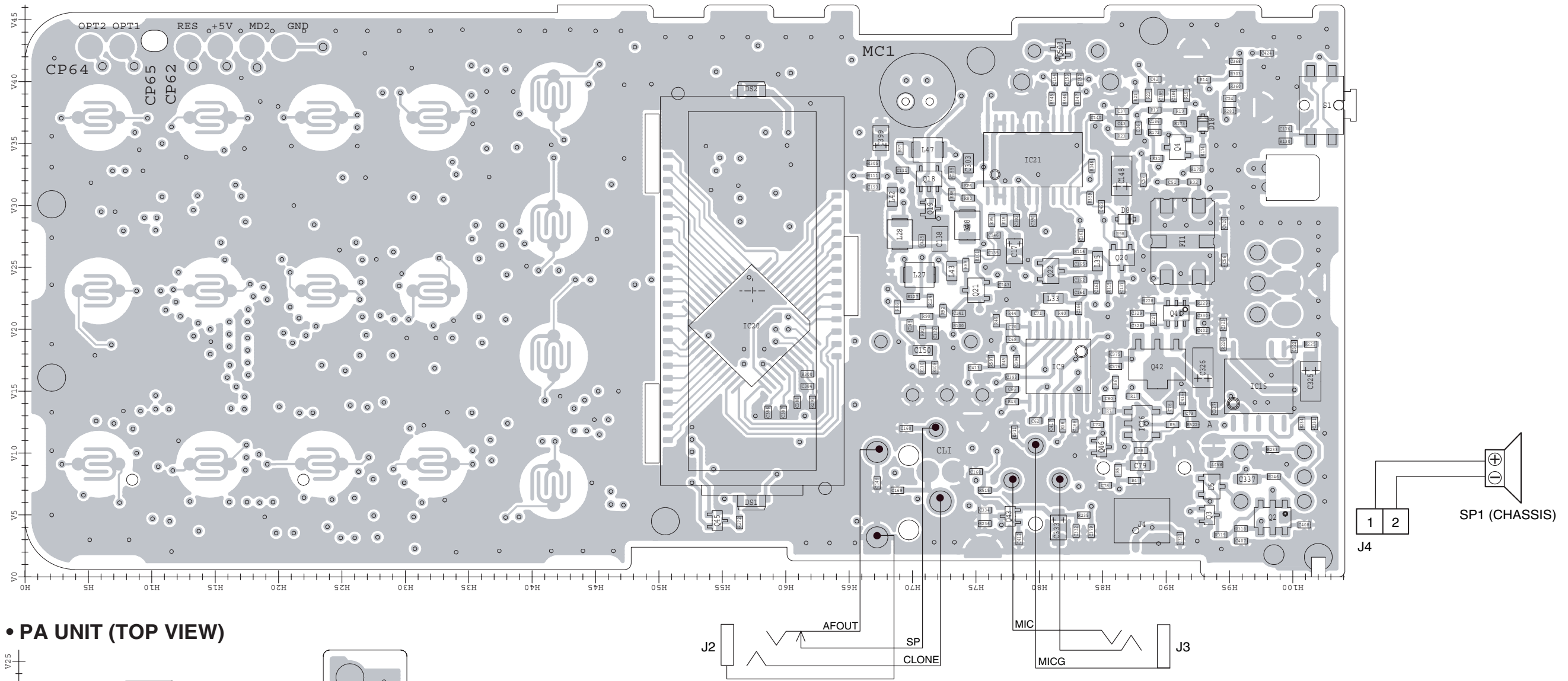

• PA UNIT (TOP VIEW)

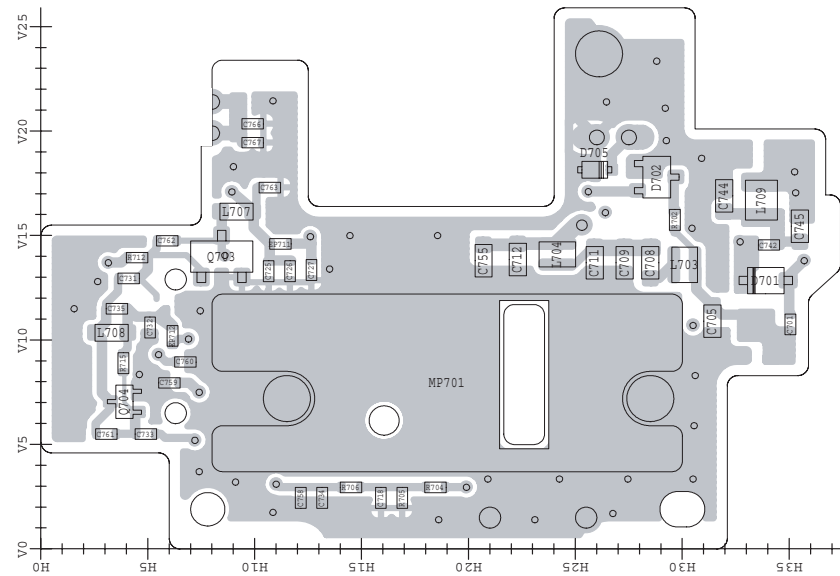

• FUSE UNIT (TOP VIEW)

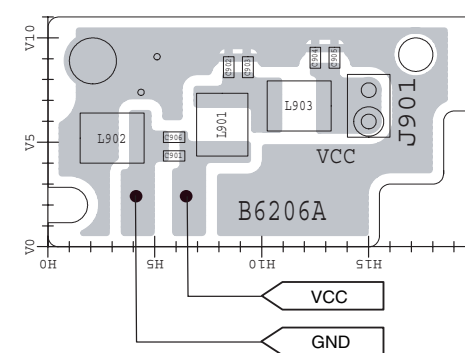

• ANT UNIT (TOP VIEW)

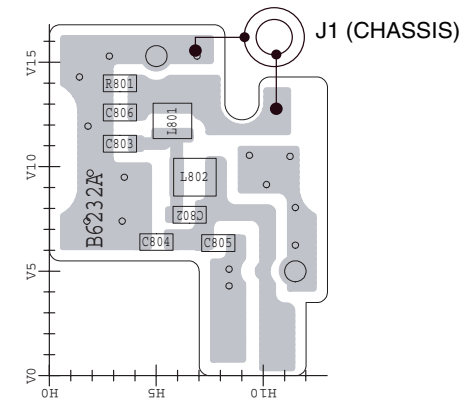

• BC-160 (TOP VIEW)

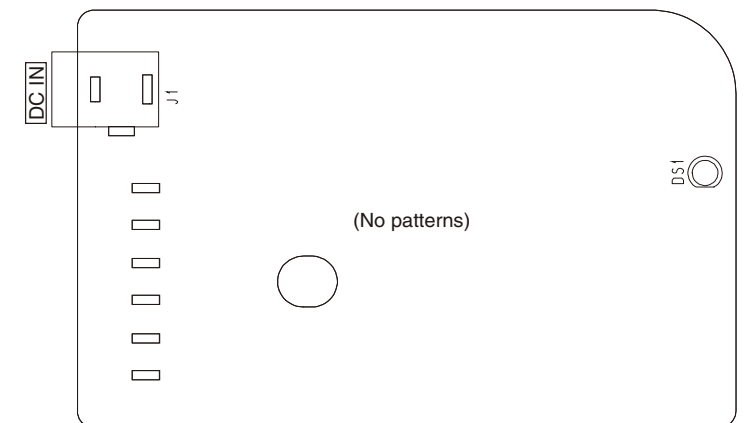

The combination of this side and the bottom side shows the board layout in the same configuration as the actual P.C.Board.

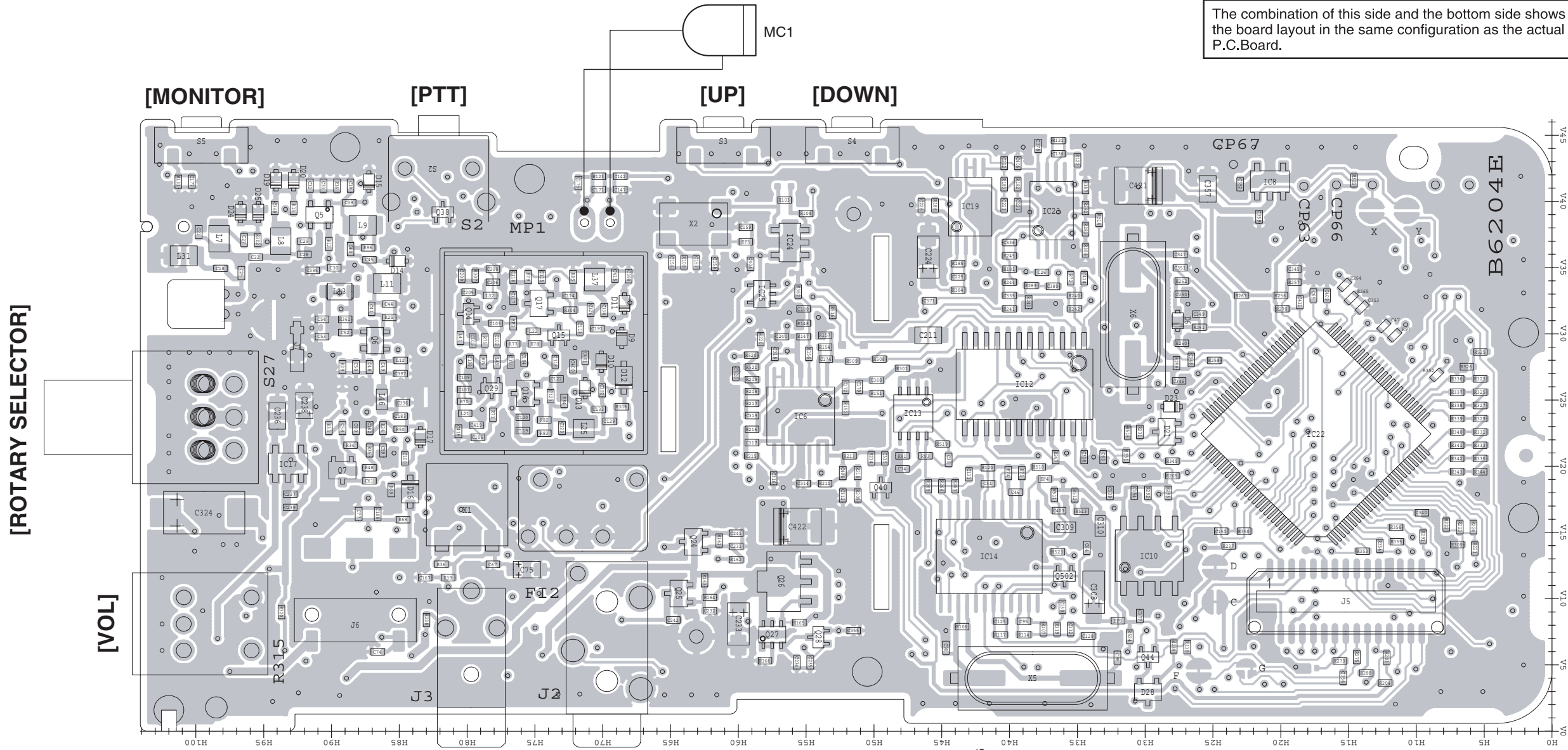

• BC-160 (BOTTOM VIEW)

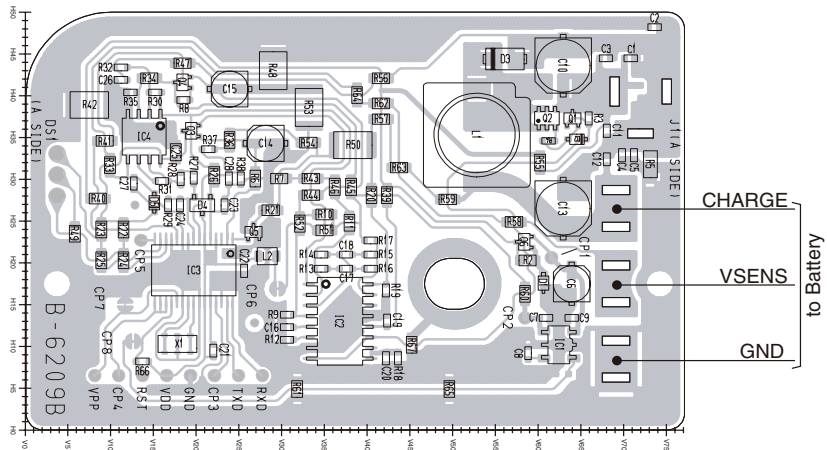

• ANT UNIT (BOTTOM VIEW)

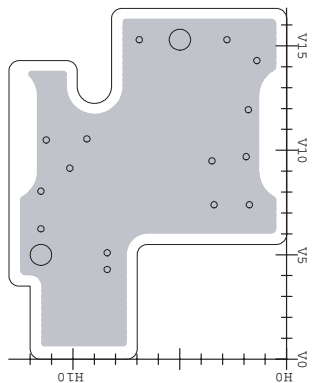

• FUSE UNIT (BOTTOM VIEW)

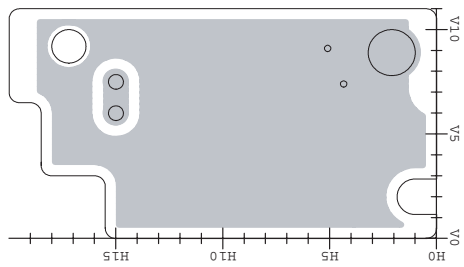

• PA UNIT (BOTTOM VIEW)

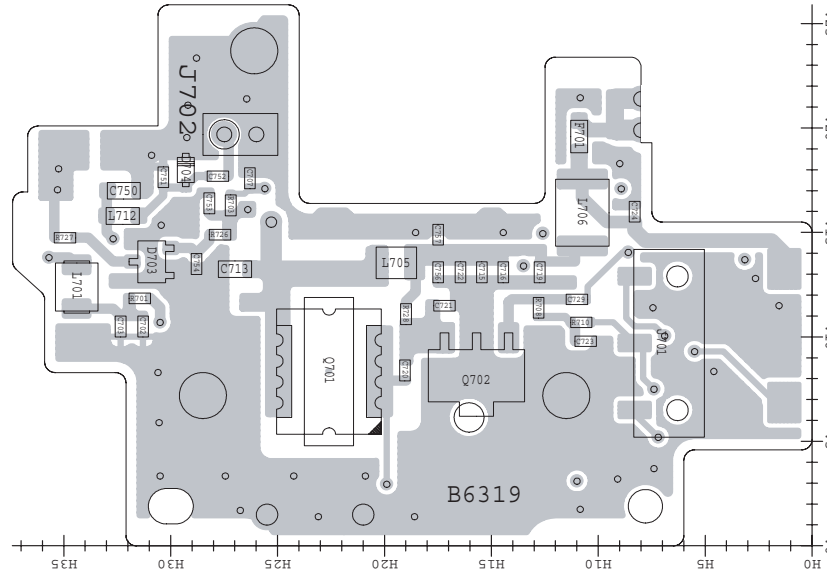

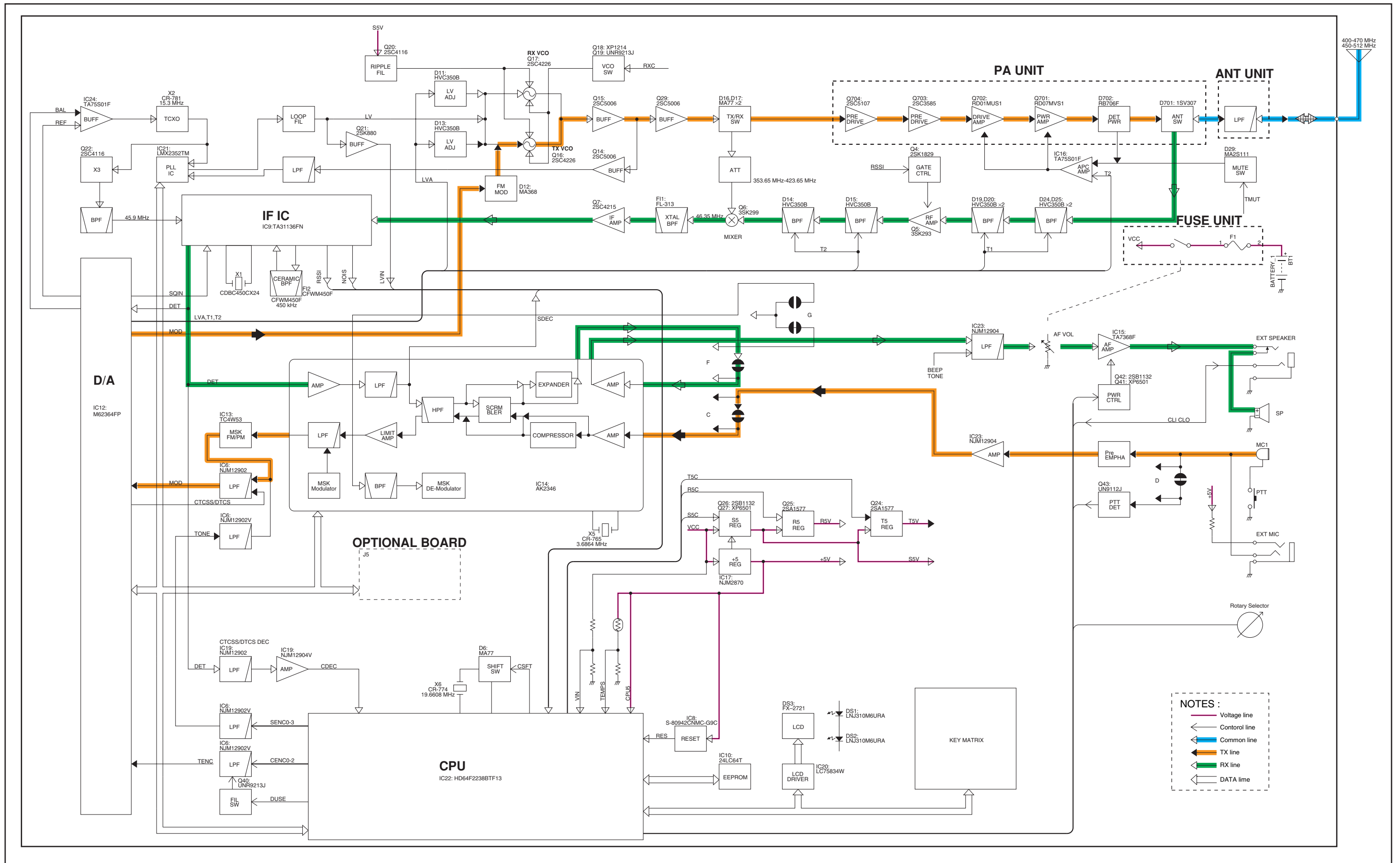

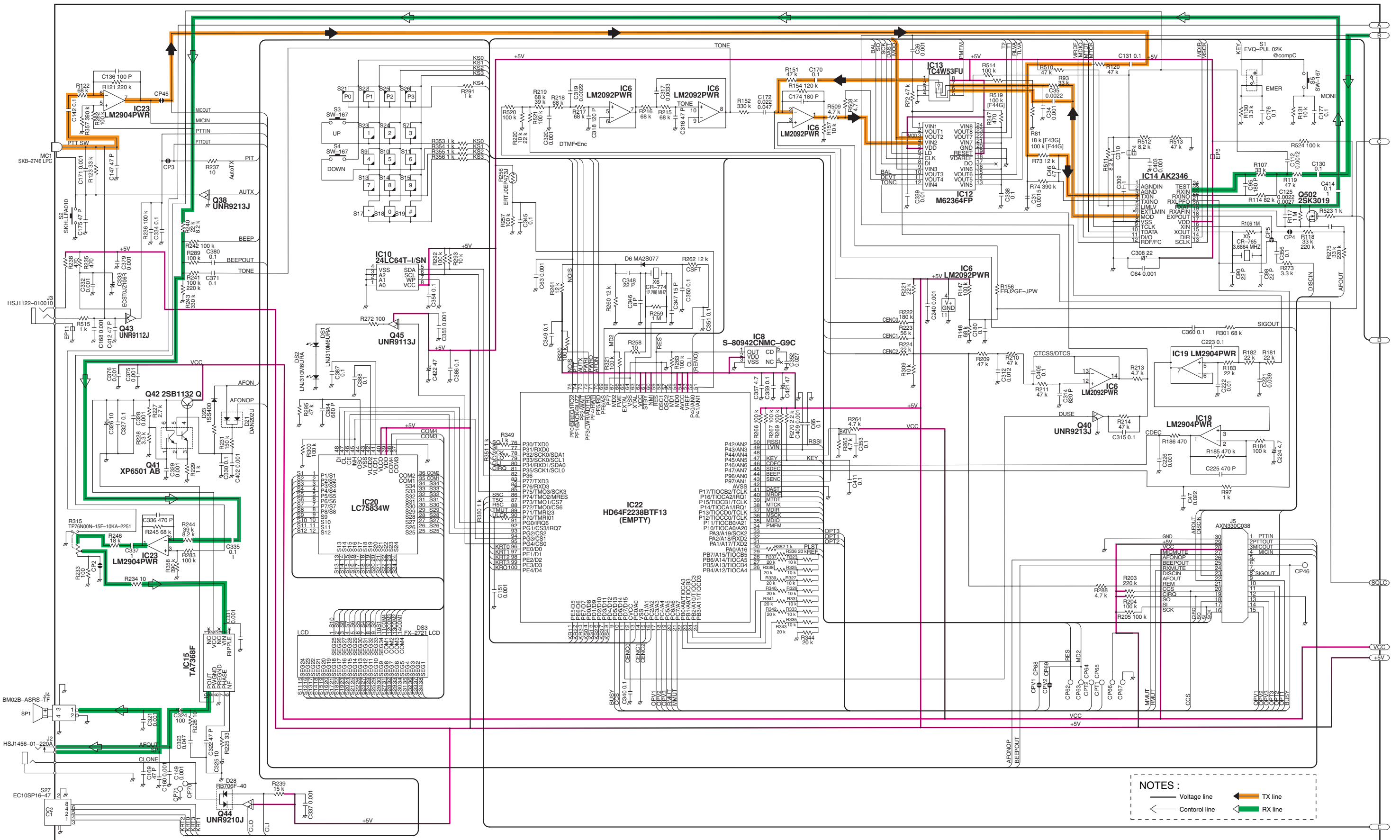

NOTES :
 — Voltage line ← TX line
 — Control line ← RX line

*; Refer to "PARTS LIST"

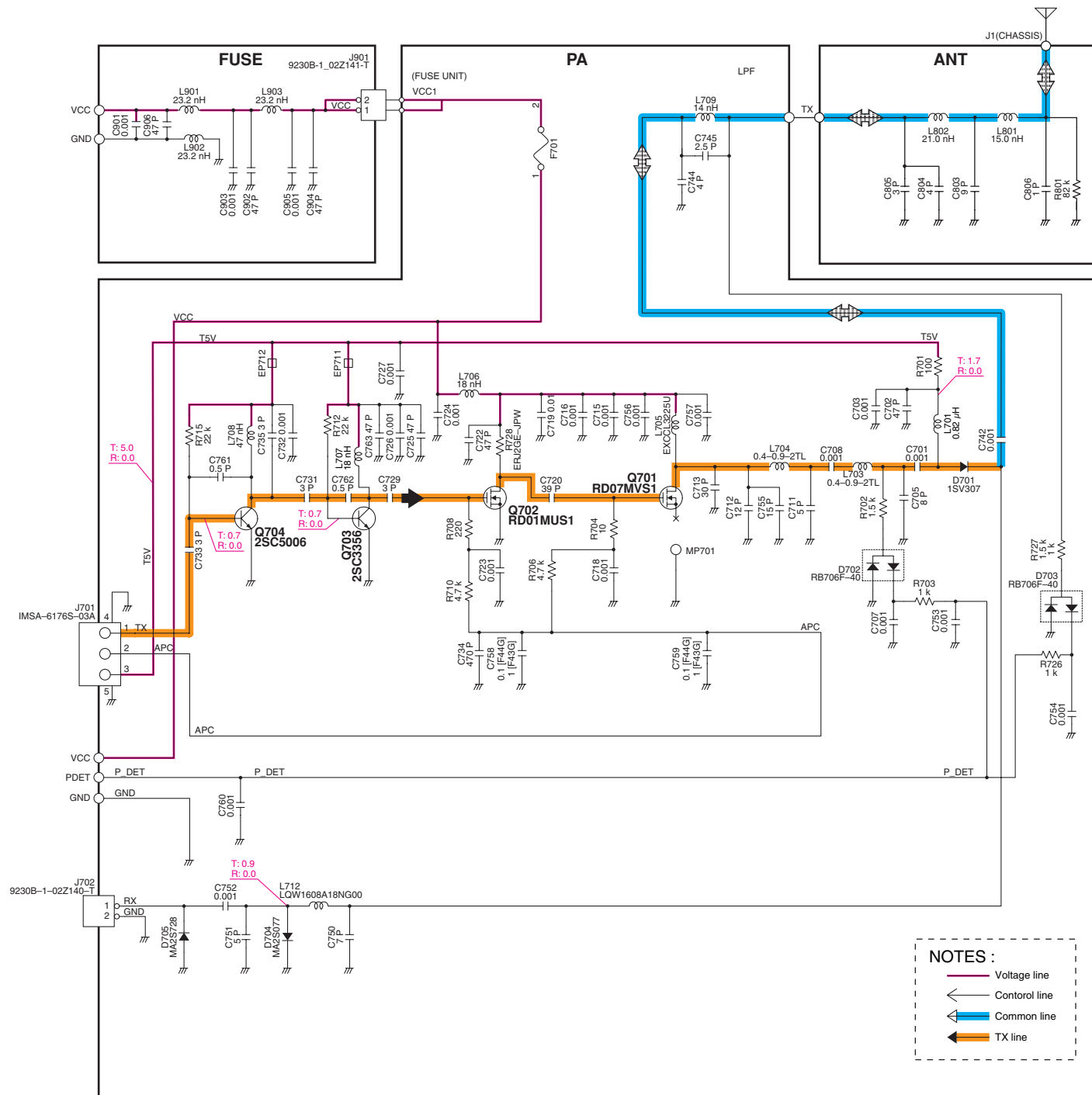

SECTION 12

BC-160

[CHASSIS PARTS]

REF. NO.	ORDER NO.	DESCRIPTION	QTY.
MP1	8010019750	2830 case	1
MP2	8110008220	2830 cover	1
MP3	8930039620	Leg cushion (A)	2
MP4	8810008630	Screw PH BT M3 x 6 NI-ZU	1

[MAIN UNIT]

REF. NO.	ORDER NO.	DESCRIPTION	QTY.
J1	6510023070	Connector HEC2305-01-250	1
DS1	5040002740	LED RT3-03HRYG	1
MP1	8930064410	2830 TERMINAL	3

[ACCESSORIES]

REF. NO.	ORDER NO.	DESCRIPTION	QTY.
EP1	Optional product	Charger BC-145E	[EUR] 1
	Optional product	Charger BC-145UK	[UK] 1

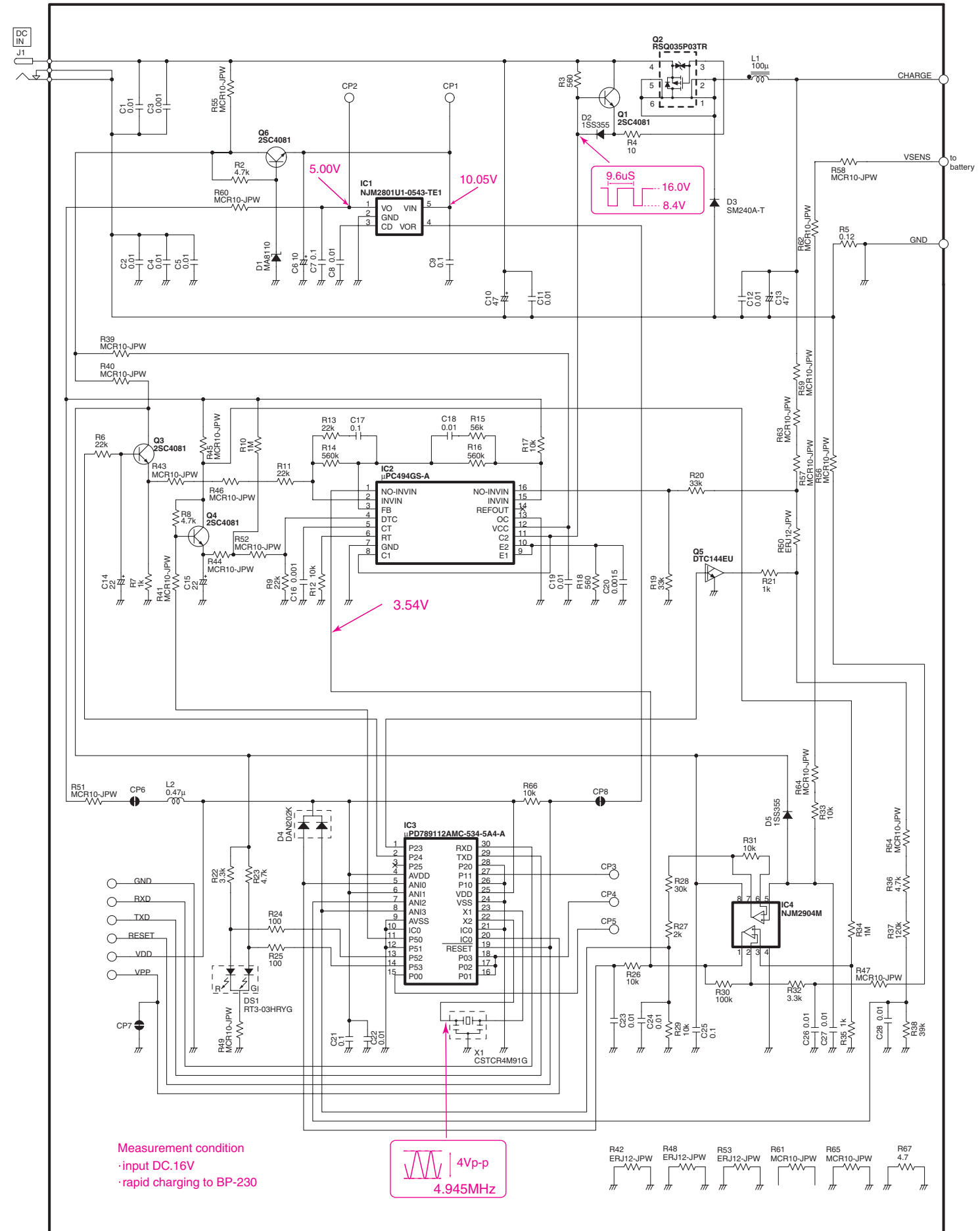
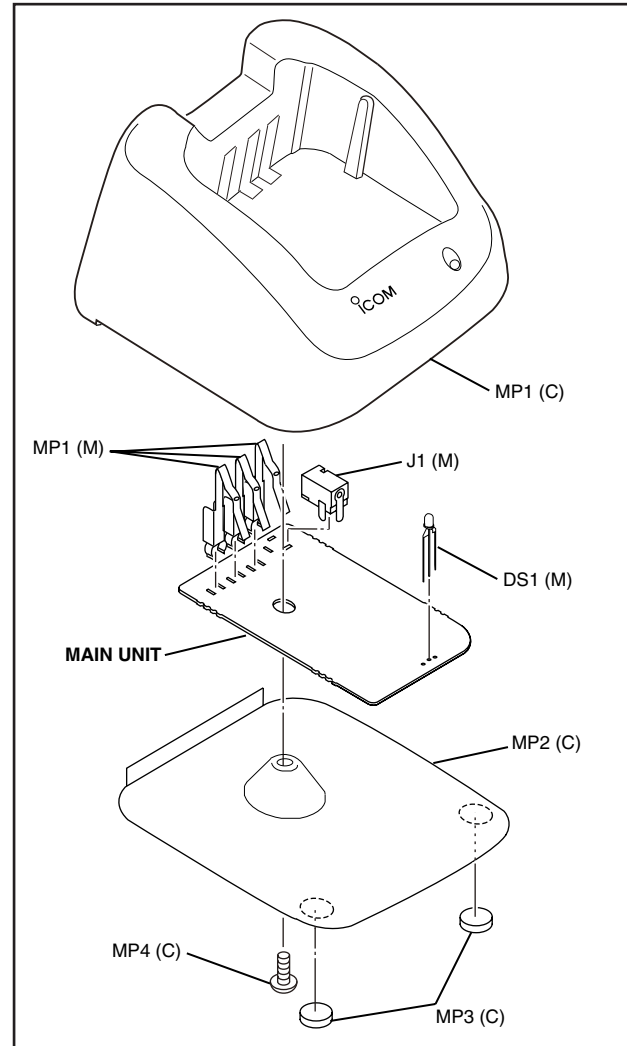

Icom Inc.

1-1-32, Kamiminami, Hirano-ku, Osaka 547-0003, Japan
Phone : +81 (06) 6793 5302
Fax : +81 (06) 6793 0013
URL : <http://www.icom.co.jp/world/index.html>

Icom America Inc.

<Corporate Headquarters>
2380 116th Avenue N.E., Bellevue, WA 98004, U.S.A.
Phone : +1 (425) 454-8155 Fax : +1 (425) 454-1509
URL : <http://www.icomamerica.com>
E-mail : sales@icomamerica.com
<Customer Service>
Phone : +1 (425) 454-7619

Icom Canada

Glenwood Centre #150-6165
Highway 17 Delta, B.C., V4K 5B8, Canada
Phone : +1 (604) 952-4266 Fax : +1 (604) 952-0090
URL : <http://www.icomcanada.com>
E-mail : info@icomcanada.com

Icom (Australia) Pty. Ltd.

Unit 1 / 103 Garden Road, Clayton VIC 3168 Australia
Phone : +61 (03) 9549-7500 Fax : +61 (03) 9549-7505
URL : <http://www.icom.net.au>
E-mail : sales@icom.net.au

Icom New Zealand

146A Harris Road, East Tamaki,
Auckland, New Zealand
Phone : +64 (09) 274 4062 Fax : +64 (09) 274 4708
URL : <http://www.icom.co.nz>
E-mail : inquiries@icom.co.nz

Beijing Icom Ltd.

Room C01, 10th Floor, Long Silver Mansion, No. 88,
Yong Ding Road, Haidian District, Beijing, 100039, China
Phone : +86 (010) 5889 4250 Fax : +86 (010) 5889 4250
URL : <http://www.bjicom.com>
E-mail : bjicom@bjicom.com

Icom (Europe) GmbH

Communication Equipment
Himmelgeister Str. 100, D-40225 Düsseldorf, Germany
Phone : +49 (0211) 346047 Fax : +49 (0211) 333639
URL : <http://www.icomeurope.com>
E-mail : info@icomeurope.com

Icom Spain S.L

Ctra. Rubi, 88, 08190, Sant Cugat del Valles, Barcelona, SPAIN
Phone : +34 (93) 590 26 70 Fax : +34 (93) 589 04 46
URL : <http://www.icomspain.com>
E-mail : icom@icomspain.com

Icom (UK) Ltd.

Unit 9, Sea St., Herne Bay, Kent, CT6 8LD, U.K.
Phone : +44 (01227) 741741 Fax : +44 (01227) 741742
URL : <http://www.icomuk.co.uk>
E-mail : info@icomuk.co.uk

Icom France s.a.s.

Zac de la Plaine
1 Rue Brindejonc des Moulinais BP 5804
31505 Toulouse Cedex, France
Phone : +33 (5) 61 36 03 03 Fax : +33 (5) 61 36 03 00
URL : <http://www.icom-france.com>
E-mail : icom@icom-france.com

Asia Icom Inc.

6F No.68, Sec. 1 Cheng-Teh Road, Taipei, Taiwan, R.O.C.
Phone : +886 (02) 2559 1899 Fax : +886 (02) 2559 1874
URL : <http://www.asia-icom.com>
E-mail : sales@asia-icom.com

Icom Polska

Sopot, 3 Maja 54 Poland
Phone : +48 (58) 550 7135 Fax : +48 (58) 551 0484
E-mail : icompolaska@icompolaska.com.pl

Count on us!

Icom Inc.

1-1-32, Kamiminami, Hirano-ku, Osaka 547-0003, Japan

S-14108IZ-C1-①
© 2004-2007 Icom Inc.